

PRESSURE SWITCH

**FEATURES**

- 316 Stainless Steel Enclosure
- Hermetically Sealed Switch
- SPDT or DPDT Switch Output
- Range Adjustability:
2 to 9000 psi
(0,1 to 620,5 bar)
- 72" Leadwires



OVERVIEW

United Electric's 360 Series adjustable pressure switch is a compact design for low, mid and high-pressure applications. The housing and pressure port are made of 316 Stainless Steel. The switch housing is a welded, hermetically sealed, explosion proof assembly available as a single pole double throw (SPDT) or double pole double throw (DPDT) configuration. An internal, slotted pressure adjustment wheel is accessible through a tethered cover plate for easy setting and field adjustment. The combination of 316 Stainless Steel construction and hermetically sealed switching make the 360 Series particularly well suited for various oil & gas applications including offshore platforms, safety panels, and pipelines, as well as other hazardous location process applications.

FEATURES

- Compact Design
- cULus listed and certified, and ATEX compliant for Div. 1 and Zone 1 hazardous locations
- Enclosure type 4X, IP66 certified
- Convenient Field Adjustments
- Adjustable set point range to 9000 psi
- CE compliance to Low Voltage Directive and Pressure Equipment Directive
- Optional pressure connections and integrated pressure snubber

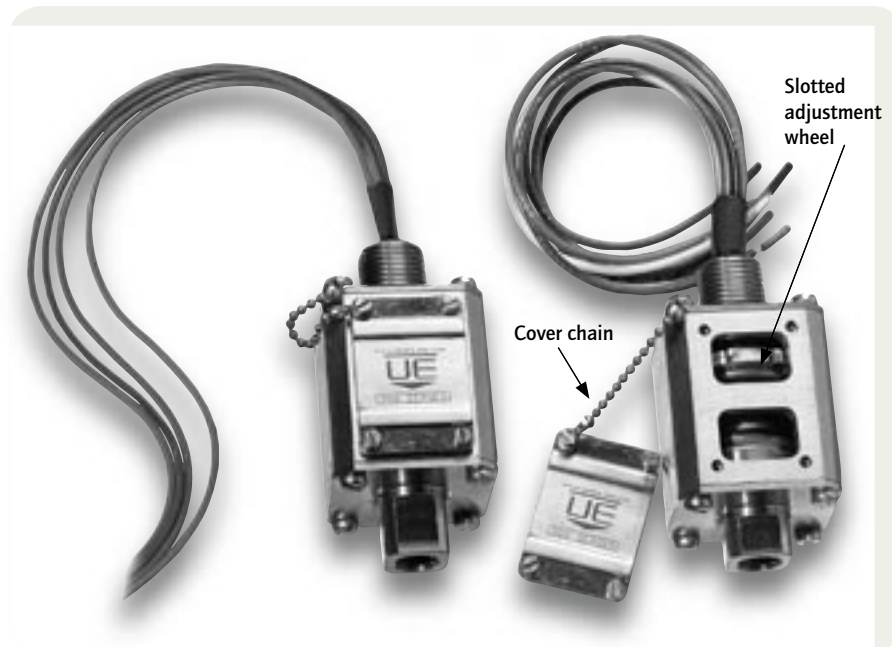

APPLICATIONS

UE's 360 Series pressure switches are used in both critical and non-critical applications, monitoring product, process and hydraulic pressures. When hazardous conditions are detected, 360 Series pressure switches are used to trigger alarms or engage safety shutdowns, protecting people, processes and equipment. A sampling of typical applications are:

- Well head safety shutdown
- Blow out Preventors (BOP)
- Hydraulic pressure safety panels
- Low limit & high limit shutdowns on rotating equipment
- Sand probes & pipeline integrity
- Solenoid valve control

Offshore Platforms (exploration & production)



Offshore Stainless Steel Safety Panel

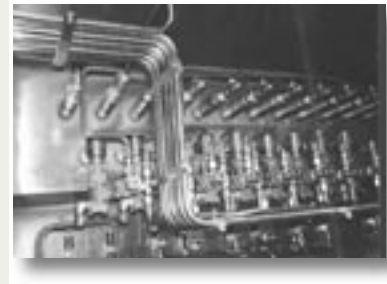

Pipeline (oil & gas transmission)



Chemical Plants & Refineries



SPECIFICATIONS

STORAGE TEMPERATURE:	-58° to 203°F (-50° to 95°C)
OPERATING AMBIENT TEMPERATURE:	-58° to 203°F (-50° to 95°C). Set point shifts less than 1% of range for a 50°F (28°C) ambient temperature change
MEDIA TEMPERATURE:	Model 360: -50° to 350°F (-46° to 177°C) Models 361 & 362: -10° to 200°F (-23° to 93°C)
SET POINT REPEATABILITY:	Model 360: +/- 1% of adjustable range; Models 361 & 362: +/- 1.5% of adjustable range
SHOCK:	Set point repeats after 75G's, 10 milliseconds (except Model 360, range A in the inverted position which is 40G's 10 milliseconds)
ENCLOSURE:	316 stainless steel
ENCLOSURE CLASSIFICATION:	Enclosure type 4X; IP66 certified. Class I, Division 1 product is designed to meet enclosure type 7. Class II, Division 1 product is designed to meet enclosure type 9
SWITCH OUTPUT:	Code S: One SPDT, hermetically sealed Code D: Two SPDT for DPDT action, hermetically sealed
ELECTRICAL RATINGS:	5 A @ 125/250 VAC resistive and 3 A @ 28 VDC inductive
ELECTRICAL CONNECTION:	1/2" NPT (male) with 72" leadwires
WEIGHT:	Approximately 29 ounces (0,82 kg)
PRESSURE CONNECTION:	1/4" NPT (female) or 1/2" NPT (female) (SF-250-CX Autoclave available on Model 361)

APPROVALS



UNITED STATES AND CANADA

Class I, Division 1 & 2, Groups A, B, C & D

Class II, Division 1 & 2, Groups E, F & G

Class III

Class I, Zone 1, Group IIC

Enclosure Type 4X

UL Listed, cUL Certified

Pressure: UL 508, 698; CSA C22.2 No. 14-M91, 25-1966, 30-1986, CEC Part I - File #E40857



EUROPEAN UNION

CENELEC/DEMKO A/S (N.B. #0539)

Demko A/S certified to **ATEX** Directive (94/9/EC)

II 2 G EEx d IIC T6, Tamb.. -50°C to +80°C (-58°F to +176°F), IP 66

II 2 D T+85°C, Tamb.= -50°C to +80°C (-58°F to +176°F), IP 66

EN 50 014, EN 50 018, EN 50 281, EN 60529

Certificate #DEMKO 03 ATEX 0334782X



CENELEC/TÜV Süddeutschland Bau und Betrieb GmbH (N.B. #0036)

TÜV certified to PED (97/23/EC)

Category IV, Module H1 (must select option M407)

Certificate #USA 02/04/38/001 thru USA 02/07/38/033



UEC Compliant to LVD (73/23/EC & 93/68/EEC)

Products rated lower than 50 VAC and 75 VDC are outside of the scope of the LVD
The Low Voltage Directive does not apply to products for use in hazardous locations

PRESSURE MODEL CHART

Range Code	Adjustable Range		Deadband		Over Range Pressure*		Proof Pressure**			
	psi	bar	psi	bar (unless noted)	psi	bar	psi	bar		
Model 360 , welded Inconel® diaphragm with 316 stainless steel pressure connection										
A	2 to 22	0,1 to 1,5	0.4 to 3.5	27,6 mbar to 0,2 bar	600	41,4	1200	82,7		
B	12 to 90	0,8 to 6,2	1 to 12	0,1 to 0,8	600	41,4	1200	82,7		
Model 362 , 303 stainless steel piston and Buna N O-Ring with 316 stainless steel pressure connection										
A	55 to 300	3,8 to 20,7	10 to 35	0,7 to 2,4	3000	206,8	4500	310,3		
B	150 to 650	10,3 to 44,8	15 to 75	1,0 to 5,2	3000	206,8	4500	310,3		
			Lower 75% range span		Top 25% range span		Over Range Pressure*		Proof Pressure**	
			psi	bar	psi	bar	psi	bar	psi	bar
Model 361 , 303 stainless steel piston and Buna N O-Ring & Teflon® seal with 316 stainless steel pressure connection										
A	475 to 1500	32,8 to 103,4	50 to 175	3,4 to 12,1	325 psi max	22,4	6500	448,2	18500	1275,5
B	900 to 3000	62,1 to 206,8	80 to 300	5,5 to 20,7	600 psi max	41,4	9000	620,5	18500	1275,5
C	1800 to 9000	124,1 to 620,5	150 to 1000	10,3 to 68,9	2000 psi max	137,9	10000	689,5	18500	1275,5

***Over Range Pressure:** The maximum pressure that may be applied continuously without causing damage and maintaining set point repeatability.

****Proof Pressure:** The maximum pressure to which a pressure sensor may be occasionally subjected, which causes no permanent damage. The unit may require calibration (e.g. start-up, testing).

Deadband Notes: Model 361 ranges are expressed as the lower 75% and top 25% of the range span because of the operating characteristics of the piston/o-ring assembly.

Inconel® is a registered trademark of the INCO family of companies.

DIMENSIONAL DRAWINGS

Dimensional drawings for all models may be found at www.ueonline.com

TYPE	PORT SIZE	DIM A	DIM B
360	1/4" NPT	5/8"	3/4"
	1/2" NPT	1"	1"
361	1/4" NPT	1-1/16"	3/4"
	1/2" NPT	1-1/2"	1"
	Autoclave, SF-250-CX	1-1/16"	15/16"
362	1/4"	1-1/16"	3/4"
	1/2"	1-1/2"	1"

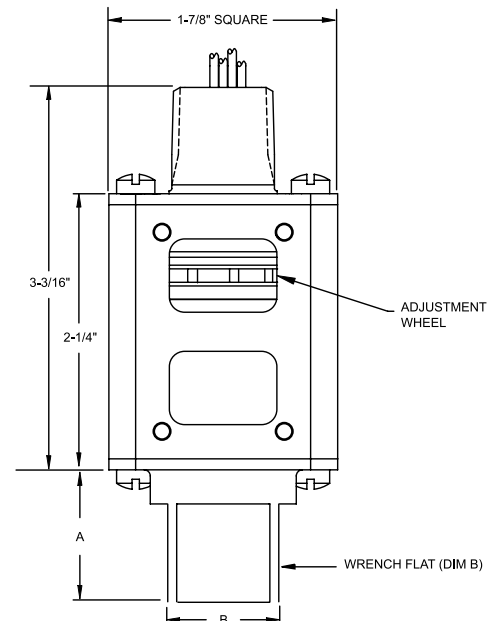



HOW TO ORDER

Select letter or number codes to make up part number.

361	1	B	S	1	M201
Model	Pressure Connection	Range	Switch Output	Enclosure Material	Options

ORDERING CODE	DESCRIPTION	361	1	B	S	1	M201
MODEL DESIGNATION							
360	Low Pressure Switch						
361	High Pressure Switch						
362	Mid Pressure Switch						
PRESSURE CONNECTION							
1	1/4" NPT (female)						
2	1/2" NPT (female)						
4	SF-250-CX Autoclave female (available on model 361 only)						
RANGE							
A	See model chart, page 5, for range specifications						
B	See model chart, page 5, for range specifications						
C	See model chart, page 5, for range specifications						
SWITCH OUTPUT							
S	SPDT						
D	DPDT						
ENCLOSURE MATERIAL							
1	316 stainless steel						
OPTIONS							
0140*	Gold contacts, 1 A @ 125 VAC resistive, 0.5 A @ 28VDC inductive						
M201	Factory set switch, specify increasing or decreasing pressure						
M276	Range indicated on nameplate in bar or mbar, factory selected						
M277	Range indicated on nameplate in kPa or MPa , factory selected						
M278	Range indicated on nameplate in Kg/cm ²						
M407	CE compliance to pressure equipment directive (category IV). Nameplate will reflect range in bar and notified body #0036						
M423	ATEX flameproof compliant junction box, pre-wired (not UL approved)						
M444	Paper ID tag						
M446	Stainless steel ID tag and wire attachment						
M460	External ground screw; required for non-metallic conduit systems (ATEX installations only)						
M513	UL approved, explosion proof junction box, pre-wired (not approved for ATEX or as enclosure type 4X)						
M515	DIN connector - 4 terminal; conforms to DIN 43650, Form A (not approved for Class I, Div. 1 & 2 or ATEX flameproof requirements). Not available on DPDT switch output						
M540	Viton® O-ring plus standard connection material (deadband and low end of range may increase slightly). Not available on Model 360						
M550	Oxygen service cleaning; internal construction and materials may change (includes Viton® O-ring when applicable)						
M928	Stainless steel pressure snubber integrated into pressure connection. Not available model 360, and autoclave pressure connection						
NC1	NACE Certificate. Not available on models 361, 362						

Viton® is a registered trademark of Dupont Dow Elastomers.

* Switch has limited DC capabilities. Consult factory for details.

ALTERNATIVE PRODUCTS FROM UE

TX200 Series Pressure Transmitters

- Welded, hermetically sealed, 316 Stainless steel construction
- Ranges 0 to 100 psi up to 0 to 24,000 psi
- Choice of field or factory-sealed zero and span calibration
- 4-20 mA or 1-5 VDC output

**Spectra 12 Series**

- Compact, cylindrical stainless steel design
- Hermetically-sealed switch
- Explosion-proof
- Snap-acting belleville spring mechanism to enhance vibration resistance and set point stability
- Pressure ranges 1 to 6000 psi; DP working pressure ranges 0 to 2500 psid; temperature ranges -130 to 650°F

**120 Series**

- Explosion-proof line of pressure, differential pressure, and temperature models with wide selection of ranges, sensors and pressure connections
- UL, cUL, ATEX certified for hazardous locations
- Single or dual switch outputs
- Internal or external set point adjustment

**One Series 2-Wire & 4-Wire Electronic Pressure and Temperature Switches with I Am Working Diagnostics Signal**

- Solid-state reliability with health-checking diagnostics
- Available with innovative low power "2-Wire" model for discrete input to PLC's or DCS; or models to switch 24-280 VAC @ 10 Amps
- Enclosure type 4X design, approved for Class I, Division 2 hazardous or intrinsically safe locations
- Digital display and tamper-proof keypad adjustment of setpoint and deadband

**P100 Deep Submersible Industrial Pressure Transducer**

- Choice of pressure fittings is 1/4-18 NPT (female) and 7/16-20 SAE female
- Submersible up to 10,000 feet
- Monel housing provides excellent resistance to saltwater
- Pressure ranges from 0-50 through 0-10,000 psi
- 0-5 VDC and 4-20 mA



RECOMMENDED PRACTICES AND WARNINGS

United Electric Controls Company recommends careful consideration of the following factors when specifying and installing UE pressure and temperature units. Before installing a unit, the Installation and Maintenance instructions provided with unit must be read and understood.

- To avoid damaging unit, proof pressure and maximum temperature limits stated in literature and on nameplates must never be exceeded, even by surges in the system. Operation of the unit up to maximum pressure or temperature is acceptable on a limited basis (e.g., start-up, testing) but continuous operation must be restricted to the designated adjustable range. Excessive cycling at maximum pressure or temperature limits could reduce sensor life.
- A back-up unit is necessary for applications where damage to a primary unit could endanger life, limb or property. A high or low limit switch is necessary for applications where a dangerous runaway condition could result.
- The adjustable range must be selected so that incorrect, inadvertent or malicious setting at any range point cannot result in an unsafe system condition.
- Install unit where shock, vibration and ambient temperature fluctuations will not damage unit or affect operation. When applicable, orient unit so that moisture does not enter the enclosure via the electrical connection. When appropriate, this entry point should be sealed to prevent moisture entry.
- Unit must not be altered or modified after shipment. Consult UE if modification is necessary.
- Monitor operation to observe warning signs of possible damage to unit, such as drift in set point or faulty display. Check unit immediately.
- Preventative maintenance and periodic testing is necessary for critical applications where damage could endanger property or personnel.
- Electrical ratings stated in literature and on nameplate must not be exceeded. Overload on a switch can cause damage, even on the first cycle. Wire unit according to local and national electrical codes, using wire size recommended in installation sheet.
- Do not mount unit in ambient temp. exceeding published limits.

LIMITED WARRANTY

Seller warrants that the product hereby purchased is, upon delivery, free from defects in material and workmanship and that any such product which is found to be defective in such workmanship or material will be repaired or replaced by Seller (Ex-works, Factory, Watertown, Massachusetts. INCOTERMS); provided, however, that this warranty applies only to equipment found to be so defective within a period of 24 months from the date of manufacture by the Seller. Seller shall not be obligated under this warranty for alleged defects which examination discloses are due to tampering, misuse, neglect, improper storage, and in any case where products are disassembled by anyone other than authorized Seller's representatives. EXCEPT FOR THE LIMITED WARRANTY OF REPAIR AND REPLACEMENT STATED ABOVE, SELLER DISCLAIMS ALL WARRANTIES WHATSOEVER WITH RESPECT TO THE PRODUCT, INCLUDING ALL IMPLIED WARRANTIES OF MERCHANTABILITY OR FITNESS FOR ANY PARTICULAR PURPOSE.

LIMITATION OF SELLER'S LIABILITY

Seller's liability to Buyer for any loss or claim, including liability incurred in connection with (i) breach of any warranty whatsoever, expressed or implied, (ii) a breach of contract, (iii) a negligent act or acts (or negligent failure to act) committed by Seller, or (iv) an act for which strict liability will be inputted to seller, is limited to the "limited warranty" of repair and/or replacement as so stated in our warranty of product. In no event shall the Seller be liable for any special, indirect, consequential or other damages of a like general nature, including, without limitation, loss of profits or production, or loss or expenses of any nature incurred by the buyer or any third party.

UE specifications subject to change without notice.

U.S. SALES OFFICES

United Electric Controls
32 Highland Rd.
South Hampton, NH 03827
Phone: 603-394-0078
FAX: 603-394-0175

United Electric Controls
28 N. Wise Ave.
Freeport, IL 61032
Phone: 815-235-3501
FAX: 815-235-3847

United Electric Controls
1022 Vineyard Drive
Conyers, GA 30013
Phone: 770-483-8400
FAX: 770-929-8716

United Electric Controls
5829 Grazing Court
Mason, OH 45040
Phone: 513-398-3175
FAX: 513-398-3076

United Electric Controls
102 Salazar Court
Clayton, CA 94517
Phone: 925-524-0210
FAX: 925-524-0210

United Electric Controls
27 Summit Terrace
Sparta, NJ 07871
Phone: 973-271-2550
FAX: 973-729-6099

United Electric Controls
12630 Summerwood Glen
Houston, TX 77041
Phone: 832-243-0119
FAX: 832-243-0140

CANADA

EASTERN
68 Mosley Crescent
Brampton, Ontario
Canada L6Y 5C8
Phone: 905-455-5131
FAX: 905-455-5131

INTERNATIONAL OFFICES

BELGIUM
United Electric Controls-Europe
G. Van Gervenstraat 19A
B-9120 Beveren-Waas, Belgium
Phone: 32-37554-383
FAX: 32-37552-747

CHINA
United Electric Controls
Room 1114, No. 511
Shenshi Building
Weihai Road
Shanghai 200041, P.R. China
Phone: +8621-6255 8059
FAX: +8621-6255 8349

GERMANY
United Electric Controls
An Der Zentlinde 21
D-64711 Erbach, Germany
Phone: 496-062-7400
FAX: 496-062-7501

MALAYSIA
United Electric Controls, Far East
No. 1-2-2, 2nd Floor
Jalan 4/101C
Cheras Business Centre
Batu 5, Jalan Cheras
56100 Kuala Lumpur, Malaysia
Phone: 603-9133-4122
FAX: 603-9133-4155

RUSSIA
United Electric Controls, Moscow
Alyabyeva str., 4-1-4
Moscow, 121309, Russia
Phone: +7 (095) 792-88-06
FAX: +7 (095) 142-34-60

WESTERN
148 Silver Ridge Close N.W.
Calgary, Alberta
Canada T3B 3T4
Phone: 403-247-3724
FAX: 403-247-3724



UNITED ELECTRIC
CONTROLS

180 Dexter Avenue, P.O. Box 9143
Watertown, MA 02471-9143 USA
Telephone: 617 926-1000 Fax: 617 926-2568
<http://www.ueonline.com>