

GR

## UFM 3030 Universal 3-beam in-line ultrasonic flowmeter for liquids

- The universal process meter
- Long term stability and high reliability
- Lowers operational and maintenance costs
- At an attractive price



Electromagnetic flowmeters  
Variable area flowmeters  
Mass flowmeters

### Ultrasonic flowmeters

Vortex flowmeters  
Flow controllers  
Level measuring instruments  
Pressure and temperature  
Heat metering  
Communications technology  
Switches, counters, displays and recorders  
Engineering systems & solutions



# UFM 3030

## Universal 3-beam in-line ultrasonic flowmeter for liquids

Experience a new dimension in ultrasonic technology

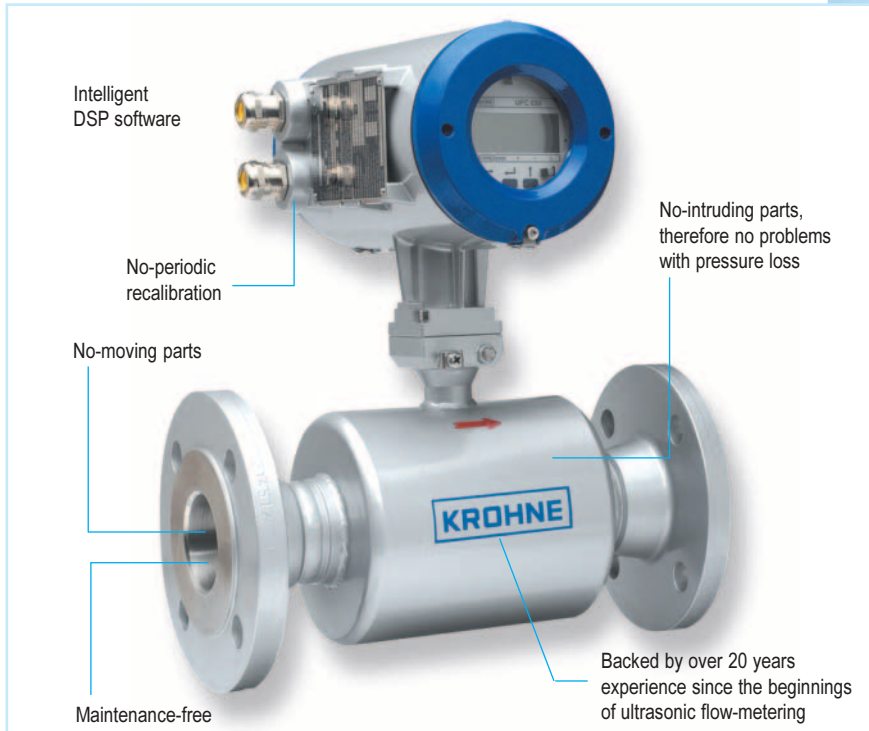

### UFM 3030

#### The ideal, universal process meter

- Metering of low-conductivity liquids, including solvents and raw materials
- Metering of cooling water
- Metering of demineralized water
- Inline flow measurement in pipelines for oil and gas products (note for custody transfer measurement, please ask for information on ALTOSONIC III)

#### Fields of application

- Chemical plants
- Refineries
- Industrial processes

### The third beam adds a new dimension!

The three measuring beams of UFM 3030 generate a 3-dimensional cross-section of the medium's velocity distribution, or flow profile, through the measuring tube. These measuring beams are positioned such that measurement is effectively independent of the flow profile.

Major performance improvements have been achieved by applying innovative electronics in combination with Digital Signal Processing (DSP). This results in stable and reliable measurements. The meter is therefore more accurate and less sensitive to changes in the flow profile, solids or entrained air. UFM 3030 is a universal meter in a very broad range of applications.

A new feature of the UFM 3030 is the possibility to control batching operations, directly from UFM 3030. Optionally, pressure and temperature inputs can be accommodated for the calculation of standardized volumetric flow or mass flow (according to API 2540 or customer specifics).

Naturally, a complete offering of communication protocols and approvals for hazardous areas makes it possible to integrate the meter into existing systems.

### Flow profile

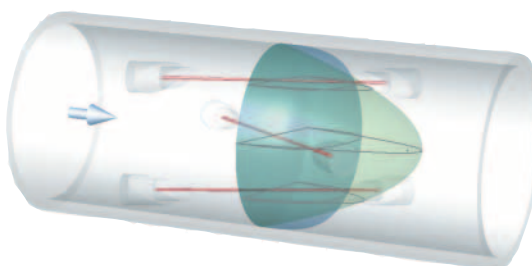

The third measuring beam allows UFM 3030 to take conditions from laminar to turbulent flow into consideration.



# Step into the new dimension!



## UFM 3030 exceeds your expectations in...

### ...Performance

UFM 3030 has a very wide application range. Three measuring beams combined with patented sensors, dedicated electronics and innovative digital signal processing techniques provide reliable, stable measurements, even under difficult process conditions. As a result, flowmeter drift and, therefore, process re-tuning has become an annoyance of the past.

### ...Installation

UFM 3030 is a light-weight, compact meter that is easy to install and operate. Additional arrangements such as filters, flow strainers, supports, grounding or isolation against vibrations are not necessary. Since the meter is maintenance-free, even installation in difficult to access locations is possible.

### ...Operational and maintenance costs

UFM 3030 has no intruding or moving parts. There is no additional pressure loss or wear and tear. Thus the meter is maintenance-free and far more energy efficient.

### ...Price

UFM 3030 is very attractively priced. The total costs of a measuring installation with UFM 3030 are considerably lower than those of a comparable installation of a coriolis mass or a vortex flowmeter. Moreover, one universal meter for all your applications keeps your engineering and inventory costs to a minimum.

## How does UFM 3030 operate?



UFM 3030 operates like all KROHNE ultrasonic flowmeters, by the transit-time differential method. This measuring principle is based on a simple physical principle.

Imagine two canoes crossing a river diagonally, one with the flow and one against the flow. Naturally, the canoe that is travelling with the flow will reach the opposite side sooner than the canoe that is travelling upstream. Acoustic signals behave in a comparable way.

By means of 3 pairs of patented ultrasonic transducers, the transit times of acoustic signals that travel upstream and downstream are measured.

The difference in transit time is proportional to the mean flow velocity and is converted into an output signal and display of volumetric flow rate and total.

The measuring beams in a UFM 3030 make a three-dimensional cross section of the velocity distribution or flow profile of the medium flowing through the measuring tube. These measuring lines are positioned so that the influence by flow profile (laminar or turbulent) is reduced greatly. Combined with the use of the latest digital processing techniques, the results are stable and reliable flow measurements.

Day in, day out. Year in, year out. There is no drift in measurements, and repeatable process control is achieved.

### Laminar flow

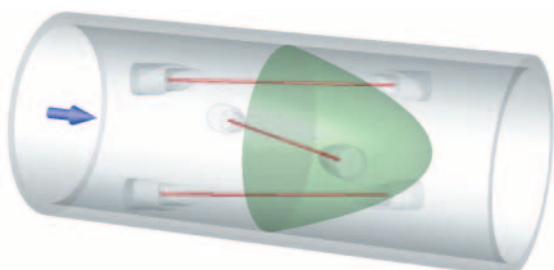

### Turbulent flow

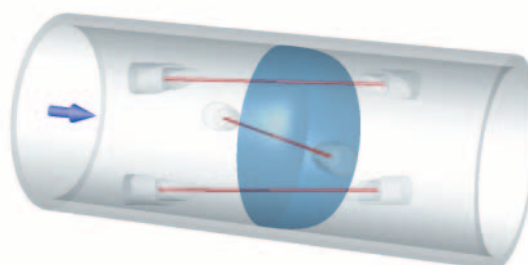

Ultrasonic flowmeter UFM 3030

Versions

The UFS 3000 ultrasonic flow sensor is combined with the UFC 030 ultrasonic flow converter to make a complete flowmeter, the UFM 3030 ultrasonic flowmeter, either in separate or compact version. Both the sensor and the converter are approved for use in hazardous areas.

	UFM 3030 K (compact)	<input checked="" type="radio"/>	UFC 030 K ultrasonic flow converter directly mounted on the UFS 3000 ultrasonic flow sensor
	UFM 3030 F (separate)	<input type="radio"/>	Separate Version UFC 030 F ultrasonic flow converter is remotely mounted from the UFS 3000
<b>Performance</b>	Measurement functionality	<input checked="" type="radio"/>	Actual volume with simple single stage batching function
		<input type="radio"/>	Corrected or standardized volume flow rate to API 2540 or customer specified
		<input type="radio"/>	Customer specified mass flow (requires customer data)
		<input type="radio"/>	Thermal energy measurement
	Measuring range		v = 0 to 20 m/s (0 ft/s to 66 ft/s)
Measuring error (under reference conditions)		v = 0.5 to 20 m/s (1.5 to 60 ft/s) <math>\pm 0.5\%</math> of measured value v < 0.5 m/s (1.5 ft/s) <math>\pm 2.5\text{ mm/s}</math> (<math>\pm 0.1\text{ inch/s}</math>) of measured value	
Repeatability (under reference conditions)		$\pm 0.2\%$ of measured value	
Process conditions		Maximum solid particle content < 5% (by volume) Maximum gas content < 2% (by volume)	
<b>Communication protocol</b>		<input checked="" type="radio"/>	HART®
		<input type="radio"/>	Profibus PA
<b>Approvals</b>	EEx zone 1 (ATEX)	UFM 3030 K-EEx	II 2 G EEx d [ib] IIC T6 ...T3 or II 2 G EEx de [ib] II C T6 ... T3
		UFM 3030 K/i-EEx	II 2 G EEx d [ia/ib] IIC T6 ...T3 or II 2 G EEx de [ia/ib] II C T6 ... T3
		UFS F 3000/F-EEx	II 2 G EEx ib IIC T6 ...T3
		UFC 030/F-EEx	II 2 G EEx d [ib] IIC T6 or II 2 G EEx de [ib] II C T6
		UFC 030/F/i-EEx	II 2 G EEx d [ia/ib] IIC T6 or II 2 G EEx de [ia/ib] II C T6
FM			FM Class I, Div. 1 & 2, Groups A, B, C & D
			FM Class II, Div. 1, Groups E, F & G and Div. 2, Groups F & G
			FM Class III, Div. 1 & 2
CSA			CSA Class I, Div. 1 & 2, Groups A, B, C & D
			CSA Class II, Div. 1 & 2, Groups E, F & G
			CSA Class III, Div. 1
<b>Protection category</b>	to IEC 529 (EN 60 529)	<input checked="" type="radio"/>	(separate and compact versions) IP 67 (equivalent to NEMA 6 and 6P)
		<input type="radio"/>	separate version IP 65 (equivalent to NEMA 4 and 4X) or IP 68 (equivalent to NEMA 6 and 6P)

Standard  Optional - On request

Temperature Limits

°C	Process temp.		Ambient temp.		°F	Process temp.		Ambient temp.	
	min.	max.	min.	max.		min.	max.	min.	max.
<b>Compact</b>	-25	140	-40	65	<b>Compact</b>	-13	284	-40	149
<b>Separate</b>	-25	180	-40	65	<b>Separate</b>	-13	356	-40	149
<b>XT version*</b>	-25	220	-40	65	<b>XT version*</b>	-13	428	-40	149

\* Up to DN 150/6" only.

Special versions

HT version available on request for product temperatures ranging from -170°C to +500°C (-274°F to +932°F).

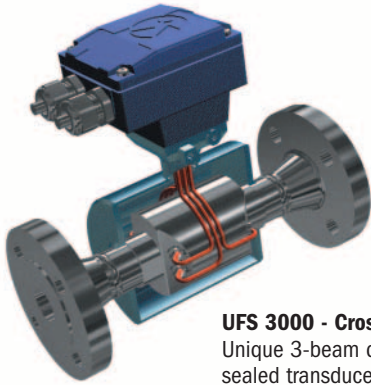

**UFS 3000 - Cross section**  
Unique 3-beam design with hermetically sealed transducers

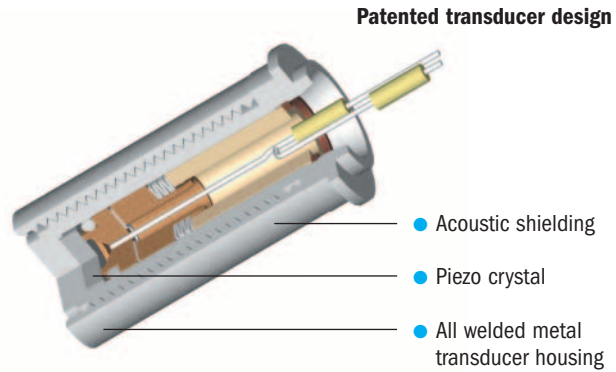

- Acoustic shielding
- Piezo crystal
- All welded metal transducer housing

**Ultrasonic flow sensor UFS 3000**

Nominal diameter	ANSI [inch]	1"	1 1/4"	1.5"	2"	2.5"	3"	4"	5"	6"	8"	10"	12"	14"	16"	18"	20"	24"	28"	32"	36"	40"	48"	56"	64"	72"	80"
	DN [mm]	25	32	40	50	65	80	100	125	150	200	250	300	350	400	450	500	600	700	800	900	1000	1200	1400	1600	1800	2000
Pressure class*	DIN 2635 - PN 40	●	●	●	●	●	○	○	○	○	○	○	○	○	○	○	○	○	○	○	○	○	○	○	○	○	○
	DIN 2634 - PN 25	-	-	-	-	-	-	○	○	○	○	○	○	○	○	○	○	○	○	○	○	○	○	○	○	○	○
	DIN 2633 - PN 16	○	○	○	○	○	○	●	●	●	○	○	○	○	○	○	○	○	○	○	○	○	○	○	○	○	○
	DIN 2632 - PN 10	-	-	-	-	-	-	-	-	-	●	●	●	●	●	●	●	●	●	●	●	●	●	●	●	●	●
	DIN 2631 - PN 6	-	-	-	-	-	-	-	-	-	-	-	-	-	-	-	-	-	-	-	-	-	-	●	●	●	●
	JIS 10 K	-	-	-	●	●	●	●	●	●	●	●	●	●	●	●	●	●	●	●	●	●	●	●	●	●	●
	JIS 20 K	●	●	●	-	-	-	-	-	-	-	-	-	-	-	-	-	-	-	-	-	-	-	-	-	-	-
			ASME B16.5														ASME B16.47, A										
150 lbs RF	●	●	●	●	●	●	●	●	●	●	●	●	●	●	●	●	●	●	●	●	●	●	●	●	●	●	
300 lbs RF	-	-	-	-	-	-	○	○	○	○	○	○	○	○	○	○	○	○	○	○	○	○	○	○	○	○	
600 lbs RF/RTJ	-	-	-	-	-	-	-	-	-	-	-	-	-	-	-	-	-	-	-	-	-	-	-	-	-	-	
900 lbs RF/RTJ	-	-	-	-	-	-	-	-	-	-	-	-	-	-	-	-	-	-	-	-	-	-	-	-	-	-	

\* Other combinations of diameter/pressure class are available on request.  
For detailed overview, see the dimensions and weights tables in this datasheet.

Applied materials*	Flanges	● SS 316 L(14404)	● Carbon Steel
	Measuring tube	● SS AISI 316 L (1.4404)	● Carbon Steel
	Housing	● SS AISI 316 L (14404)	● Carbon Steel ● individual SS 316 L external transducer housing
	Connection box	● Die-cast aluminium ○ Stainless steel	
	Transducer window	● Stainless steel AISI 316 L (1.4408)	

\*Other materials (e.g. Duplex) available on request

Finish*	Polyurethane coated	●
	Offshore paint system, silver	○

\*Other paint systems on request.

Calibration	2 points, with water	●
	According to RvA	○

Protection category to IEC 529	IP 67 eq. NEMA 6	●
	IP 68 eq. NEMA 6P	○ (for separate flow sensor only)

Sensor cable connection (for separate versions)	M20 x 1,5	●
	1/2" NPT	○
	PF 1/2	○

Sensor cable length (for separate versions)	5 m / 15 ft	●
	10 m / 30 ft	○
	15 m / 45 ft	○
	Cable type MR06, 20 m / 60 ft	○
	O.D. = 11 mm / 0.43" 25 m / 75 ft	○
	30 m / 90 ft	○

● Standard ○ Optional - On request

**UFC 030 Ultrasonic Flow converter**

The converter has a backlit local display with three push buttons. All operation can be done by using the push buttons or with the aid of a hand-held bar magnet, without opening the converter housing. The compact converter (UFC 030 K) is mounted directly on the flow sensor, while the separate version (UFC 030 F) is supplied with a bracket for wall or pipe mounting.

The converter is fully digitised. Measured values are obtained by use of DSP (Digital Signal Processing) ensuring stable readings, even under severe process conditions. The converter has standard HART® communication and is optionally available with Profibus.



**Ultrasonic flow converter UFC 030**      ● Standard    ○ Optional

<b>General</b>	The converter has a backlit local display with three push buttons. All operation can be done by push button or using a hand-held bar magnet, without opening the converter housing.	
<b>Applied materials</b>	Converter housing	<ul style="list-style-type: none"> <li>● Die-cast aluminum</li> <li>○ Stainless steel 316 L (1.4404)</li> </ul>
<b>Finish</b>	Polyurethane coated	●
Other paints on request	Offshore paint system, silver	○
<b>Protection category</b>	IP 67 eq. NEMA 6 to IEC 529	●
<b>Overall functionality / Measurements available</b>	<ul style="list-style-type: none"> <li>● Continuous measurement of actual volume flow rate and actual volume total</li> <li>● HART® communication</li> <li>● Flow direction (forward or reverse)</li> <li>● Velocity of Sound (VOS)      ● Signal strength</li> <li>● Self diagnostics              ● Simple single stage batching</li> <li>○ Corrected or standardized volume flow rate to API 2540 or customer specified</li> <li>○ Customer specified mass flow (requires customer data)</li> <li>○ Profibus PA                      ○ Thermal energy measurement</li> </ul>	
<b>Local display</b>	Operation	With cover removed, all display operations incl. changing settings and parameters can be done using the push buttons. With cover in place the measured values and (error) messages can be viewed. Error resetting is still possible; in this case only with the aid of a hand-held bar magnet.
	3-field LCD	The converter has a backlit local display with 3 push buttons. 1st line 8 character 7 segment alphanumeric display and symbols for key acknowledgement 2nd line 10 character, 14 segment text display 3rd line 5 markers to identify display in measuring mode
	Parameters	<ul style="list-style-type: none"> <li>● Actual volume flow rate in m<sup>3</sup>, barrels, liters, US gallons or user defined volume unit per hour, minute, second, or user defined time unit</li> <li>● Actual volume total in m<sup>3</sup>, barrels, liters, US gallons or user defined volume unit (positive, negative, and sum totals), minimum 1 year overflow time</li> <li>○ Velocity of sound in m/s or ft/s</li> <li>○ Errors (flashing display and error code)      ○ Signal strength (in dB)</li> <li>● Corrected standard volume flow rate in m<sup>3</sup>, barrels, liters, US Gallons or user defined volume unit per hour, minute, second or user-defined time unit</li> <li>○ Calculated mass flow rate in user defined mass unit</li> <li>○ Corrected standard volume total in m<sup>3</sup>, barrels, liters, US Gallons or user defined corrected volume unit, minimum 1 year overflow time</li> <li>○ Calculated mass total in user defined unit, minimum 1 year overflow time</li> <li>○ Analog input in °C, °F, bar or psig</li> <li>○ Thermal power                  ○ Thermal energy totalized</li> </ul>

Ultrasonic flowmeter UFM 3030

<b>Languages</b>	English	<input checked="" type="radio"/>
	German / French	<input type="radio"/>
<b>Galvanic isolation</b>	All inputs and outputs are galvanically isolated from the power supply, but not from each other	
<b>Time constant</b>	0.025 - 99 seconds (programmable in increments of 0.01; 0.1 and 1.0 seconds)	
<b>Low-flow cut-off</b>	Cut-off active value 1 - 19% programmable in increments of 1%	
	Cut-off de-active value 2 - 20%	
<b>Power supply</b>	Power cons. approx. 10 VA (AC) or approx. 10 W (DC)	<input checked="" type="radio"/> Mains supply 100 – 240 V AC (48-63 Hz) +10% / -15% <input type="radio"/> Low voltage supply 24 V (AC or DC), AC: -10% / +15%, DC: 18 - 35 V
	<b>Cable connection</b>	<input checked="" type="radio"/>
(for power supply and signal cables)	M20 x 1,5	<input checked="" type="radio"/>
	1/2" NPT	<input type="radio"/>
	PF 1/2	<input type="radio"/>

Outputs and inputs

<b>Current output</b>	<b>Function</b>	<input checked="" type="radio"/> Continuous measurement of actual volume flow rate
		<input checked="" type="radio"/> Flow direction indication (forward or reverse)
		<input checked="" type="radio"/> Velocity of Sound (VOS)
		<input checked="" type="radio"/> Transducer signal gain (dB)
		<input type="radio"/> Corrected or standardized volume flow rate to API 2540 or customer specified
		<input type="radio"/> Customer specified mass flow (requires customer data)
<b>Settings</b>	for Q = 0%	0 - 16 mA programmable in increments of 1mA (Limit 20 - 22 mA)
	for Q=100%	4 – 20 mA
<b>Connection</b>	Active mode	using internal power supply 24 V DC, Load ≤ 680 Ohm
	Passive mode	external voltage 18 ... 24 V DC, load ≤ 680 Ohm
<b>Pulse output</b>	<b>Function</b>	<b>Pulse output</b> Pulse per volumetric unit (m3, barrels, liters, US gallons or user defined volume unit per hour, minute, second or user defined time unit)
		<input checked="" type="radio"/> Actual volume
		<input type="radio"/> Corrected or standardized volume to API 2540 or customer specified
		<input type="radio"/> Customer specified mass (requires customer specific density input)
		<input type="radio"/> Thermal energy measurement
		<b>Frequency output</b> Pulse rate
		<input checked="" type="radio"/> Continuous measurement of actual volume flow rate
		<input checked="" type="radio"/> Velocity Of Sound (VOS)
		<input checked="" type="radio"/> Transducer signal gain (dB)
		<input checked="" type="radio"/> Pressure or temperature indication based on analog input (1) or (2)
		<input type="radio"/> Corrected or standardized volume flow rate to API 2540 or customer specified
		<input type="radio"/> Customer specified mass flow (requires customer specific density input)
		<b>Status output</b>
		<input checked="" type="radio"/> Diagnostics alarm path errors, totalizer overrun, all errors, analog input
<input checked="" type="radio"/> Flow direction indication (forward or reverse)		
<input checked="" type="radio"/> Batch volume reached		
<input checked="" type="radio"/> Alarm trip point (high and low) based on actual volume flow rate		
<b>Settings</b>	<b>Pulse output</b>	Pulse/unit (max. 2000 Hz) (example 1000 pulses/barrel) pulse duty cycle 25, 50, 100, 200, or 500 ms for frequency < 10 Hz
	<b>Frequency output</b>	0 to 2 000 Hz (example Q0% - 0 Hz, Q100% - 1000 Hz) at 100% of scale value, max. frequency = 2 kHz
	<b>Status output</b>	On or Off
<b>Connection</b>	<b>Pulse, frequency and status output</b>	
	Active	Connection to electronic counters using internal power supply 24 V DC / I ≤ 50 mA
	Passive	Connection to electronic (EC) or electromechanical counters (EMC) external voltage, ≤ 19 - 32 VDC / I ≤ 150 mA

Analog input	Function	<input type="radio"/> Corrected volume version: inputs to connect temperature and pressure signals for the corrected standard volume, according to API 2540, user defined volume or mass flow	
	Setting	<input checked="" type="radio"/> Input A1	For volume correction, unit °Celsius or °Fahrenheit Temperature for 4-20 mA, max. temperature range -50°C to 150°C (-58°F to 302°F)
		<input type="radio"/> Input A2	For volume correction (pressure), unit bar or psi Pressure for 4-20 mA, max. pressure range 0 to 100 Bar (0 to 1450 psi)
	Connection	Input A1	4-20 mA for temperature sensor Active (using UFC 030 24 V DC power) or passive, Load 58 Ohm
Input A2		4-20 mA for pressure Active (using UFC 030 24 V DC power) or passive, Load 58 Ohm	
		<input type="radio"/> Thermal energy measurement: inputs to connect two temperature sensors for measurement of temperature difference in order to calculate	
	Setting	<input checked="" type="radio"/> Input A1	For heat measurement (temperature), unit °Celsius or °Fahrenheit Temperature for 4-20 mA, max. temperature range -50°C to 150°C (-58°F to 302°F)
		<input checked="" type="radio"/> Input A2	For heat measurement (temperature), unit °Celsius or °Fahrenheit Temperature for 4-20 mA, max. temperature range -50°C to 150°C (-58°F to 302°F)
	Connection	Input A1	4-20 mA for temperature sensor Active (using UFC 030 24 V DC power) or passive, Load 58 Ohm
Input A2		4-20 mA for temperature Active (using UFC 030 24 V DC power) or passive, Load 58 Ohm	
Control input	Function	<input type="radio"/> Reset totalizer <input type="radio"/> Acknowledge errors <input type="radio"/> Force outputs to zero <input type="radio"/> Initiate batch (see operating instructions for description of this function)	
	Setting	On or Off	
	Connection	Input voltage (U <sub>in</sub> )	Low: U <sub>in</sub> < 5 V (off) High: U <sub>in</sub> > 15 V (on) Max.: U <sub>in</sub> = 32 V

## Electrical connections

Please refer to the instruction manual in the Download Center of the KROHNE internet site on [www.krohne.com](http://www.krohne.com) or detailed information on how to connect signal inputs and outputs.



### Standard connection

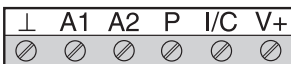

### Profibus connection

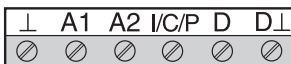

### Ex-connection (Standard)



### Ex-i connection (Modis)



### Ex-i connection with Profibus



**10** Ground connection, not for protective earthing

**L / 1L~** Live power supply

**N / 0L~** Neutral power supply

PE Protective earth connection

FE Functional earth connection

**⊥** Common ground

**A1** Analog input 1, for temperature measurement

**A2** Analog input 2, for pressure measurement

**P** Pulse, frequency or status output

**I/C** Combined Current output (I) and Digital/control input (C)

Current output (I) incl. HART communication

**V+** DC power supply from converter for active wiring of inputs and outputs

**D** Profibus communication connection +

**D-** Profibus communication -

**P/I/C** Combined current output (I), digital/control (C) and pulse output (P).

See individual I/C terminal and P terminal functions

**⊥** Ground connection

**I** Current output

**B1** Pulse, frequency or status output

**B-** Ground

**n.c.** Not connected

**Sizing**

Choosing the correct size meter is very simple due to the extremely wide range of possible velocities, from 0.5 m/s (1.5 ft/sec) all the way up to 20 m/s (66 ft/sec). Below 0.5 m/s (1.5 ft/sec) the stated accuracy begins to degrade, but measurement is still possible all the way to zero flow.

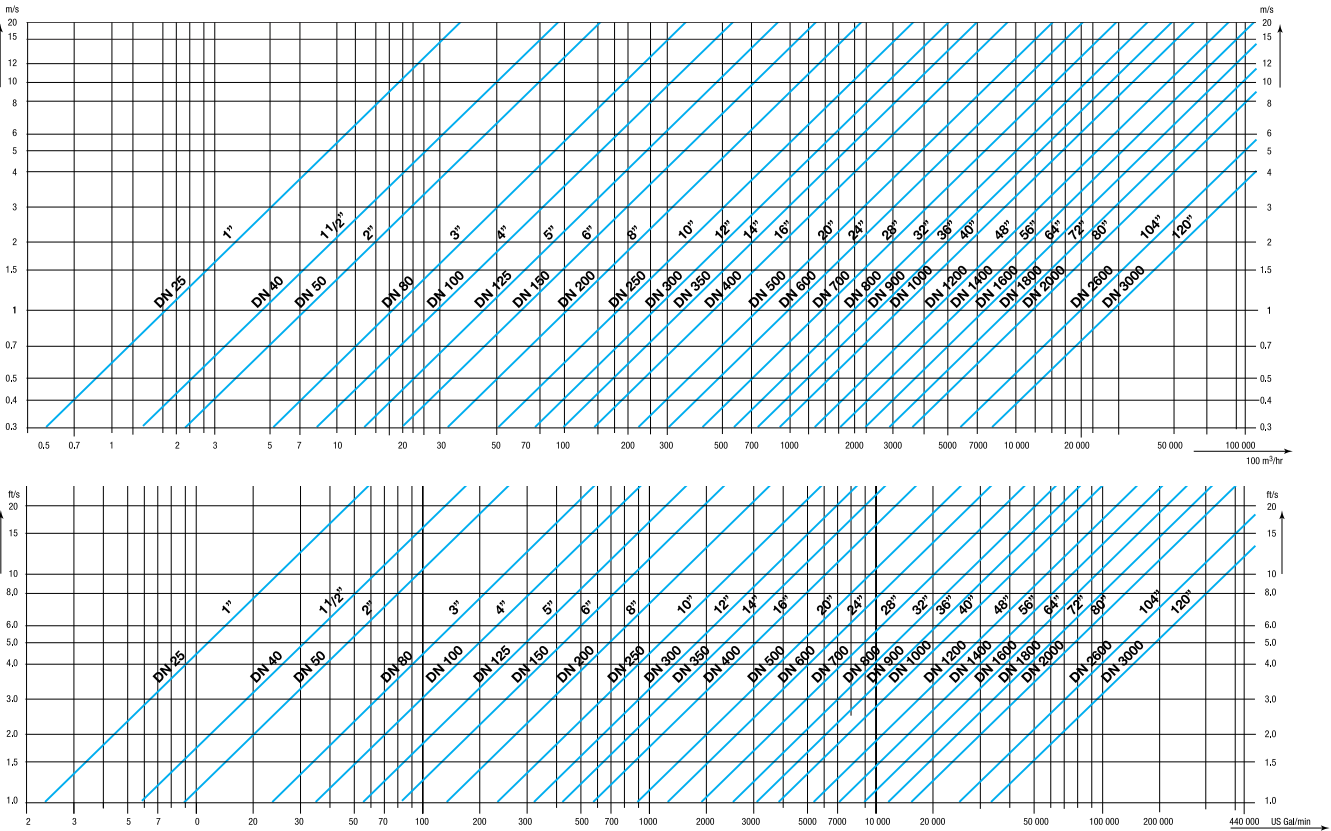

**Installation**

The flowmeter can be installed in a horizontal or a vertical position.

● **Completely filled flow sensor**

Install the UFS 3000 ultrasonic flow sensor at a location where it will be completely filled under all circumstances, including zero flow velocity.

● **Flow conditioning**

To maintain flow measurement within the stated accuracy under all circumstances, it is required to install 10D of straight pipe section before and 5D after the flow sensor. D = diameter of the flow sensor.

Deviation from these up and down stream runs may affect the accuracy of the flowmeter, not its functioning or its repeatability.

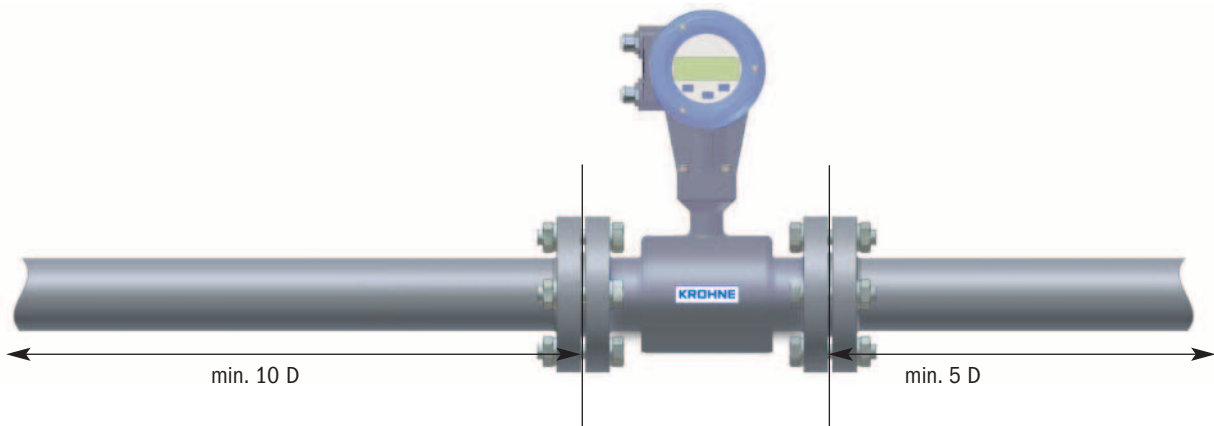

● **Zero checking**

Zero setting is not required with ultrasonic flowmeters.

For zero checking it is advised to install shutoff valves before or after the flow sensor.

For specific advice on applications exceeding these general recommendations, please consult the operating and installation instructions or contact KROHNE.

Dimensions and weights

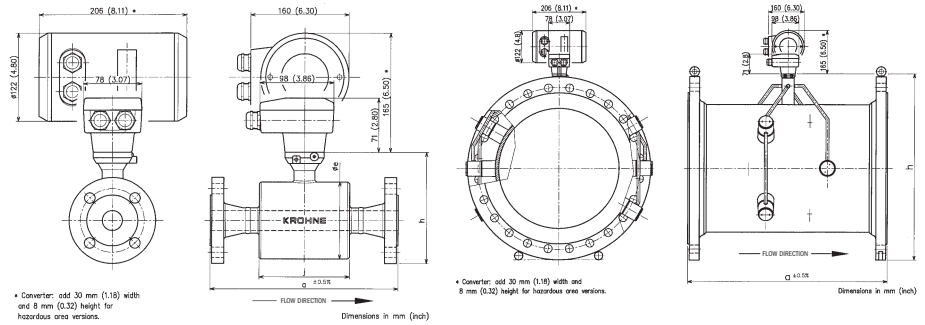

ANSI 150 lbs up to 20"

Nominal diameter	ANSI 150 lbs dimensions in mm				Approx. weight in kg*	ANSI 150 lbs dimensions in inches				Approx. weight in lbs*
	a	e	h	j		a	e	h	j	
1"	250	106	146	120	6.5	9.84	4.17	5.75	4.72	14.3
1 1/4"	260	106	152	120	7.5	10.24	4.17	5.98	4.72	16.5
1 1/2"	270	106	157	120	8.5	10.63	4.17	6.18	4.72	18.7
2"	300	133	183	152	12.5	11.81	5.24	7.20	5.98	27.6
2 1/2"	300	133	196	152	16.5	11.81	5.24	7.71	5.98	36.4
3"	350	190	234	170	17.5	13.78	7.48	9.21	6.69	38.6
4"	350	215	266	190	23.5	13.78	8.46	10.47	7.48	51.8
5"	350	237	290	210	27.5	13.78	9.33	11.42	8.27	60.6
6"	400	266	317	236	35.5	15.75	10.47	12.48	9.29	78.3
8"	400	359	395	225	66.5	15.75	14.13	15.55	8.86	146.6
10"	500	407	451	260	74.5	19.69	16.02	17.76	10.24	164.2
12"	500	457	514	290	104.5	19.69	17.99	20.24	11.42	230.4
14"	700	-	554	-	119.5	27.56	-	21.81	-	263.5
16"	800	-	612	-	158.5	31.50	-	24.09	-	349.4
18"	800	-	656	-	175.5	31.50	-	25.83	-	386.9
20"	800	-	713	-	210.5	31.50	-	28.07	-	464.1

Inner diameters based on schedule standard.

For compact (K) version: add 1.8 kg (4.0 lbs).

\*Approx. weight of flow sensor in separate (F) version.

Weight of converter in separate (F) version: 3.5 kg (7.7 lbs).

Design pressure (Calculations are based on using spiral wound gaskets)

Nominal diameter	Nominal pressure	Standard material		Design pressure (bar)				Design pressure (psi)			
		Tube	Flange	20°C	140°C	180°C	220°C	70°F	285°F	355°F	430°F
1"	150	SS 316 L	316 L	19.7	16.2	14.7	13.2	286	235	213	191
1 1/4"	150	SS 316 L	316 L	19.7	16.2	14.7	13.2	286	235	213	191
1 1/2"	150	SS 316 L	316 L	19.7	16.2	14.7	13.2	286	235	213	191
2"	150	SS 316 L	316 L	19.7	16.2	14.7	13.2	286	235	213	191
2 1/2"	150	SS 316 L	316 L	19.7	16.2	14.7	13.2	286	235	213	191
3"	150	SS 316 L	Carbon steel*	19.7	16.2	14.7	13.2	286	235	213	191
4"	150	SS 316 L	Carbon steel*	19.7	16.2	14.7	13.2	286	235	213	191
5"	150	SS 316 L	Carbon steel*	19.7	16.2	14.7	13.2	286	235	213	191
6"	150	SS 316 L	Carbon steel*	19.7	16.2	14.7	13.2	286	235	213	191
8"	150	SS 316 L	Carbon steel*	19.7	16.2	14.7	n.a.	286	235	213	n.a.
10"	150	SS 316 L	Carbon steel*	19.7	16.2	14.7	n.a.	286	235	213	n.a.
12"	150	SS 316 L	Carbon steel*	19.7	16.2	14.7	n.a.	286	235	213	n.a.
14"	150	Carbon steel	Carbon steel*	19.7	16.2	14.7	n.a.	286	235	213	n.a.
16"	150	Carbon steel	Carbon steel*	19.7	16.2	14.7	n.a.	286	235	213	n.a.
18"	150	Carbon steel	Carbon steel*	19.7	16.2	14.7	n.a.	286	235	213	n.a.
20"	150	Carbon steel	Carbon steel*	19.7	16.2	14.7	n.a.	286	235	213	n.a.

\* With carbon steel ANSI flanges please note that minimum temperature is limited to -20°C (-4°F).

For temperatures down to -25°C (-13°F) other materials are available on request.

Dimensions and weights

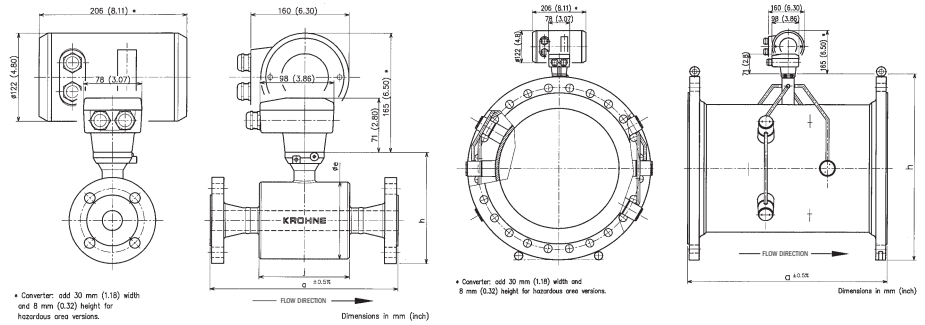

ANSI 300 lbs up to 6"

Nominal diameter	ANSI 300 lbs dimensions in mm				Approx. weight in kg*	ANSI 300 lbs dimensions in inches				Approx. weight in lbs*
	a	e	h	j		a	e	h	j	
1"	250	106	155	120	7.5	9.84	4.17	6.10	4.72	16.5
1 1/4"	260	106	160	120	8.5	10.24	4.17	6.30	4.72	18.7
1 1/2"	270	106	170	120	10.5	10.63	4.17	6.69	4.72	23.1
2"	300	133	189	152	14.5	11.81	5.24	7.44	5.98	32.0
2 1/2"	350	133	202	152	18.5	13.78	5.24	7.95	5.98	40.8
3"	350	190	244	170	21.5	13.78	7.48	9.61	6.69	47.4
4"	400	215	279	190	32.5	15.75	8.46	10.98	7.48	71.7
5"	400	237	303	210	41.5	15.75	9.33	11.93	8.27	91.5
6"	450	266	336	236	53.5	17.72	10.47	13.23	9.29	117.9

Inner diameters based on schedule standard.

\*Approx. weight of flow sensor in separate (F) version.

For compact (K) version: add 1.8 kg (4.0 lbs).

Weight of converter in separate (F) version: 3.5 kg (7.7 lbs).

Design pressure (Calculations are based on using spiral wound gaskets)

Nominal diameter	Nominal pressure	Standard material		Design pressure (bar)				Design pressure (psi)			
		Tube	Flange	20°C	140°C	180°C	220°C	70°F	285°F	355°F	430°F
1"	300	SS 316 L	316 L	51.0	45.4	44.4	43.1	740	658	644	625
1 1/4"	300	SS 316 L	316 L	51.0	45.4	44.4	43.1	740	658	644	625
1 1/2"	300	SS 316 L	316 L	51.0	45.4	44.4	43.1	740	658	644	625
2"	300	SS 316 L	316 L	51.0	45.4	44.4	43.1	740	658	644	625
2 1/2"	300	SS 316 L	316 L	51.0	45.4	44.4	43.1	740	658	644	625
3"	300	SS 316 L	Carbon steel*	51.0	45.4	44.4	43.1	740	658	644	625
4"	300	SS 316 L	Carbon steel*	51.0	45.4	44.4	43.1	740	658	644	625
5"	300	SS 316 L	Carbon steel*	51.0	45.4	44.4	43.1	740	658	644	625
6"	300	SS 316 L	Carbon steel*	51.0	45.4	44.4	43.1	740	658	644	625

\* With carbon steel ANSI flanges please note that minimum temperature is limited to -20°C (-4°F).

For temperatures down to -25°C (-13°F) other materials are available on request.

Dimensions and weights

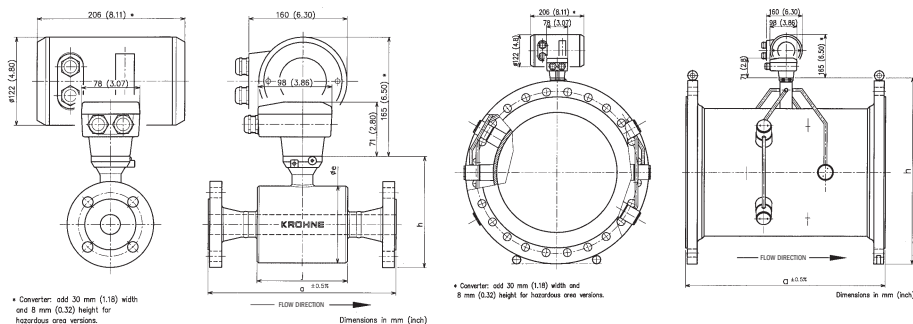

DIN as of DN 25

Nominal diameter	DIN flanges dimensions in mm				Approx. weight in kg*
	a	e	h	j	
25	250	106	150	120	6.5
32	260	106	162	120	8.5
40	270	106	167	120	9.5
50	300	133	190	152	12.5
65	300	133	200	152	15.5
80	300	190	239	170	16.5
100	350	215	262	190	18.5
125	350	237	288	210	22.5
150	350	266	320	236	27.5
200	400	359	394	225	50.5
250	400	407	445	260	60.5
300	500	457	495	290	75.5
350	500	n.a.	540	n.a.	68.5
400	600	n.a.	595	n.a.	89.5
500	600	n.a.	697	n.a.	117.5

Inner diameters based on schedule standard.

\*Approx. weight of flow sensor in separate (F) version.

For compact (K) version: add 1.8 kg (4.0 lbs).

Weight of converter in separate (F) version: 3.5 kg (7.7 lbs).

Design pressure (Calculations are based on using spiral wound gaskets)

Nominal diameter	Nominal Pressure	Standard material		Design Pressure (bar)			
		Tube	Flange	20°C	140°C	180°C	220°C
25	40	SS 316 L	SS 316	40.0	33.7	31.6	29.5
32	40	SS 316 L	SS 316	40.0	33.7	31.6	29.5
40	40	SS 316 L	SS 316	40.0	33.7	31.6	29.5
50	40	SS 316 L	SS 316	40.0	33.7	31.6	29.5
65	40	SS 316 L	SS 316	40.0	33.7	31.6	29.5
80	40	SS 316 L	Carbon steel*	40.0	33.7	31.6	29.5
100	16	SS 316 L	Carbon steel*	16.0	12.7	11.6	10.5
125	16	SS 316 L	Carbon steel*	16.0	12.7	11.6	10.5
150	16	SS 316 L	Carbon steel*	16.0	12.7	11.6	10.5
200	10	SS 316 L	Carbon steel*	10.0	7.8	7.1	n.a.
250	10	SS 316 L	Carbon steel*	10.0	7.8	7.1	n.a.
300	10	SS 316 L	Carbon steel*	10.0	7.8	7.1	n.a.
350	10	Carbon Steel	Carbon steel*	10.0	7.8	7.1	n.a.
400	10	Carbon Steel	Carbon steel*	10.0	7.8	7.1	n.a.
500	10	Carbon Steel	Carbon steel*	10.0	7.8	7.1	n.a.

\* With carbon steel DIN flanges please note that minimum temperature is limited to -10°C.

For temperatures down to -25°C other materials are available on request.







<http://www.krohne.com>

Production

**KROHNE**

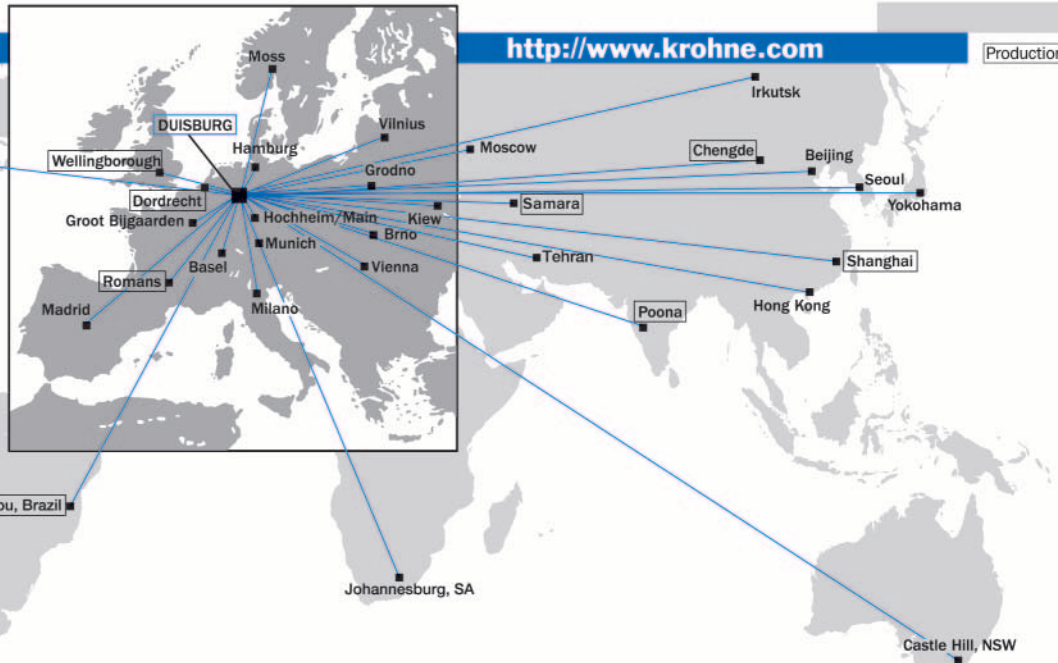

#### Australia

KROHNE Australia Pty Ltd  
Quantum Business Park  
10/287 Victoria Rd  
Rydalmere NSW 2116  
TEL: +61 2 8846 1700  
FAX: +61 2 8846 1755  
e-mail: [krohne@krohne.com.au](mailto:krohne@krohne.com.au)

#### Austria

KROHNE Austria Ges.m.b.H.  
Modecenterstraße 14  
A-1030 Wien  
TEL: +43(0)1/203 45 32  
FAX: +43(0)1/203 47 78  
e-mail: [info@krohne.at](mailto:info@krohne.at)

#### Belgium

KROHNE Belgium N.V.  
Brusselstraat 320  
B-1702 Groot Bijgaarden  
TEL: +32(0)2-4 66 00 10  
FAX: +32(0)2-4 66 08 00  
e-mail: [krohne@krohne.be](mailto:krohne@krohne.be)

#### Brazil

KROHNE Conaut  
Controles Automaticos Ltda.  
Estrada Das Águas Espraiadas, 230 C.P. 56  
06835 - 080 EMBU - SP  
TEL: +55(0)11-4785-2700  
FAX: +55(0)11-4785-2768  
e-mail: [conaut@conaut.com.br](mailto:conaut@conaut.com.br)

#### China

KROHNE Measurement Instruments  
(Shanghai) Co. Ltd., (KMIC)  
Room 1501, Tower A  
City Centre of Shanghai  
100 Zun Yi Road  
Shanghai 200051  
TEL: +86 21 6237 2770  
FAX: +86 21 6237 2771  
Cellphone: +86 (0) 139 01954185  
e-mail: [info@krohne-asia.com](mailto:info@krohne-asia.com)

#### CIS

Kanex KROHNE Engineering AG  
Business-Centre Planeta, Office 403  
ul. Marxistskaja 3  
109147 Moscow/Russia  
TEL: +7(0)095-9117165  
FAX: +7(0)095-9117231  
e-mail: [krohne@dol.ru](mailto:krohne@dol.ru)

#### Czech Republic

KROHNE CZ, spol. s r.o.  
Soběšická 156  
CZ-63800 Brno  
TEL: +420 545 532 111  
FAX: +420 545 220 093  
e-mail: [brno@krohne.cz](mailto:brno@krohne.cz)

#### France

KROHNE S.A.S.  
Les Ors  
BP 98  
F-26103 ROMANS Cedex  
TEL: +33(0)4-75 05 44 00  
FAX: +33(0)4-75 05 00 48  
e-mail: [info@krohne.fr](mailto:info@krohne.fr)

#### Germany

KROHNE Messtechnik  
GmbH & Co. KG  
Ludwig-Krohne-Str.  
D-47058 Duisburg  
TEL: +49(0)203-301-0  
FAX: +49(0)203-301-10 389  
e-mail: [krohne@krohne.de](mailto:krohne@krohne.de)

#### India

KROHNE Marshall Ltd.  
A-34/35, M.I.D.C.  
Industrial Area, H-Block,  
Pimpri Poona 411018  
TEL: +91(0)202-7442020  
FAX: +91(0)202-7442020  
e-mail: [pcu@vsnl.net](mailto:pcu@vsnl.net)

#### Iran

KROHNE Liaison Office  
North Sohrvardi Ave.  
26, Sarmad St., Apt. #9  
Tehran 15539  
TEL: ++98-21-874-5973  
FAX: ++98-21-850-1268  
e-mail: [krohne@krohneiran.com](mailto:krohne@krohneiran.com)

#### Italy

KROHNE Italia Srl.  
Via V. Monti 75  
I-20145 Milano  
TEL: +39(0)2-4 30 06 61  
FAX: +39(0)2-43 00 66 66  
e-mail: [info@krohne.it](mailto:info@krohne.it)

#### Korea

KROHNE Korea  
Room 508 Miwon Bldg  
43 Yoido-Dong  
Youngdeungpo-Ku  
Seoul, Korea  
TEL: 00-82-2-780-1743  
FAX: 00-82-2-780-1749  
e-mail: [krohnekorea@krohnekorea.com](mailto:krohnekorea@krohnekorea.com)

#### Netherlands

KROHNE Altometer  
Kerkeplaat 12  
NL-3313 LC Dordrecht  
TEL: +31(0)78-6306300  
FAX: +31(0)78-6306390  
e-mail: [postmaster@krohne-altometer.nl](mailto:postmaster@krohne-altometer.nl)

#### Netherlands

KROHNE Nederland B.V.  
Kerkeplaat 14  
NL-3313 LC Dordrecht  
TEL: +31(0)78-6306200  
FAX: +31(0)78-6306405  
Service Direkt: +31(0)78-6306222  
e-mail: [info@krohne.nl](mailto:info@krohne.nl)

#### Norway

KROHNE Instrumentation A.S.  
Ekholtveien 114  
NO-1526 Moss  
TEL: +47(0)69-264860  
FAX: +47(0)69-267333  
e-mail: [postmaster@krohne.no](mailto:postmaster@krohne.no)  
Internet: [www.krohne.no](http://www.krohne.no)

#### Singapore

Tokyo Keiso - KROHNE Pte. Ltd.  
27 Kian Teck Drive Jurong  
Singapore 628844  
Singapore  
TEL: ++65-62-64-3378  
FAX: ++65-62-65-3382

#### South Africa

KROHNE Pty. Ltd.  
163 New Road  
Halfway House Ext. 13  
Midrand  
TEL: +27(0)11-315-2685  
FAX: +27(0)11-805-0531  
e-mail: [midrand@krohne.co.za](mailto:midrand@krohne.co.za)

#### Spain

I.I. KROHNE Iberia, S.r.L.  
Poligono Industrial Nilo  
Calle Brasil, n.º. 5  
E-28806 Alcalá de Henares-Madrid  
TEL: +34(0)91-8 83 21 52  
FAX: +34(0)91-8 83 48 54  
e-mail: [krohne@krohne.es](mailto:krohne@krohne.es)

#### Switzerland

KROHNE AG  
Uferstr. 90  
CH-4019 Basel  
TEL: +41(0)61-638 30 30  
FAX: +41(0)61-638 30 40  
e-mail: [info@krohne.ch](mailto:info@krohne.ch)

#### United Kingdom

KROHNE Ltd.  
Rutherford Drive  
Park Farm Industrial Estate  
Wellingborough,  
Northants NN8 6AE, UK  
TEL: +44(0)19 33-408 500  
FAX: +44(0)19 33-408 501  
e-mail: [info@krohne.co.uk](mailto:info@krohne.co.uk)

#### USA

KROHNE Inc.  
7 Dearborn Road  
Peabody, MA 01960  
TEL: +1-978 535-6060  
FAX: +1-978 535-1720  
e-mail: [info@krohne.com](mailto:info@krohne.com)

#### Other Representatives

Algeria	Japan
Argentina	Jordan
Belarus	Kuwait
Bulgaria	Latvia
Cameroon	Lithuania
Canada	Marocco
Chile	Mauritius
Colombia	Mexico
Croatia	New Zealand
Denmark	Pakistan
Ecuador	Peru
Egypt	Poland
Estonia	Portugal
Finland	Saudi Arabia
French Antilles	Senegal
Greece	Slovakia
Guinea	Slovenia
Hong Kong	Sweden
Hungary	Taiwan
Indonesia	Thailand
Ivory Coast	Turkey
Iran	Tunisia
Ireland	Venezuela
Israel	Yugoslavia

#### Other Countries

KROHNE Messtechnik  
GmbH & Co. KG  
Ludwig-Krohne-Str.  
D-47058 Duisburg  
TEL: +49(0)203-301-309  
FAX: +49(0)203-301-389  
e-mail: [export@krohne.de](mailto:export@krohne.de)