



'INTELLIGENT' PRESSURE- AND LEVEL TRANSMITTERS

For all industries

Series 2000



- "ALL STAINLESS" DESIGN
- EASY CALIBRATION WITHOUT TEST PRESSURE BY 3 PUSH BUTTONS
- ACCURACY 0,1%
- 4-20 mA AND HART® PROTOCOL
- ATEX  II 1 G/D
- WIDE RANGEABILITY
- LOCAL DISPLAY
- ADJUSTABLE DAMPING
- MORE THAN 40 DIFFERENT PROCESS CONNECTIONS
- PROFIBUS-PA



Description

The Series 2000 is a complete range of 'intelligent' pressure and level transmitters with local display and adjustment by three pushbuttons. The pushbuttons are used to set Zero and Span. Test pressures are not required for calibration.

The display which can indicate a number of chosen engineering units is also used during programming to assist the easy operation. Process temperatures can be shown and damping times can be adjusted from 0 to 25 secs. Also a 4-20 mA Current Simulation can be performed.

The Series 2000 is **fully temperature compensated**. Over 40 different process connections are available including many flush diaphragm designs. Options include ATEX  approval, HART® protocol or PROFIBUS-PA output.

HART® is a registered trademark of the HART Communication Foundation



Stainless steel housing

 **KLAY-INSTRUMENTS B.V.**

Nijverheidsweg 5
P.O. Box 13
Tel. +31-521-591550
Fax +31-521-592046

7991 CZ DWINGELOO
7990 AA DWINGELOO
The Netherlands
Website: www.klay.nl

Series 2000

Description

The series 2000 pressure transmitter has been specially designed for measuring pressure in pulp and paper mills and similar industries where plugging is a problem. The transmitters are fully temperature compensated, and have **very strong, flush mounted diaphragms**. Zero and span can be *adjusted without test pressure* by 3 pushbuttons or by hand-held-terminal (HART®, option).



Specifications

Accuracy	: 0,1% of adjusted span
Measuring ranges	: 0 - 0,1 bar to 0 - 60 bar
Output signal	: 4 - 20 mA / 2-wire HART® protocol (option) PROFIBUS-PA (option)
Adjustment	: by 3 pushbuttons or H.H.T.
Power supply	: 12 - 40 Vdc
External load	: 600 Ohm/24V to 1400 Ohm/40V
Protection grade	: IP66
Process temperature	: -20 °C to +80 °C
Temperature effect	: ±0,015% / K
Wetted parts	: AISI 316 (standard)
Electronic housing	: AISI 304
Process connections	: See below. Also available PMC, Valcom, etc... Specify code X

Process connections



Code W
Weld-on
nipple \varnothing 33 mm



Code X12
PASVE
connection



Code S
1" BSP
(G1")

Dimensions (mm)

Code W

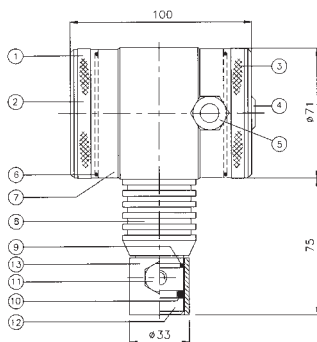

Parts description

1. Cover
2. Push buttons + display (behind cover)
3. Cover with Venting
4. Venting
5. Cable entry
6. O-ring
7. Electronics housing
8. Foot with cooling fins
9. O-ring (code W), code S = G1" thread
10. O-ring
11. M8 Bolt
12. Diaphragm
13. Weld-on nipple \varnothing 33 mm

Code S

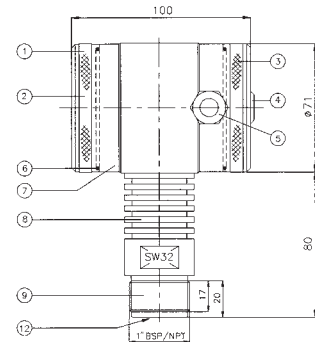

See page 6 for ordering code and ranges.

Series 2000-SAN

Description

The **2000-SAN** series are designed for all pressure and level measurements in the food and beverage, chemical and pharmaceutical industries. **All hygienic process connections are available, most of them are according to the EHEDG, 3-A and FDA regulations.** The transmitters are fully temperature compensated, and have very strong, flush mounted diaphragms. Zero and span can be *adjusted without test pressure*, over wide ranges, by 3 push-buttons, or hand-held terminal (HART®, option).



Specifications

Accuracy	: 0,1% of adjusted span
Measuring ranges	: 0 - 0,04 bar to 0 - 60 bar
Output signal	: 4 - 20 mA / 2-wire HART® protocol (option) PROFIBUS-PA (option)
Adjustment	: by 3 pushbuttons or H.H.T.
Power supply	: 12 - 40 Vdc
External load	: 600 Ohm / 24V to 1400 Ohm / 40V
Protection grade	: IP66
Process temperature	: -20 °C to +100 °C (130° / 30 min)
Temperature effect	: ±0,015% / K
Wetted parts	: AISI 316 (standard)
Option	: Hastelloy C, Tantalum or Goldplated
Electronic housing	: AISI 304
Process connections	: See below (all industrial process connections available)

Process connections



Code M
Milkcoupling
(DN 25, 40 or 50)



Code F
Flange
(DIN or ANSI)



Code W85
Weld-on nipple
ø 85 mm

Dimensions (mm)

Code F

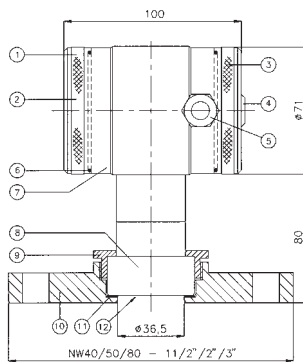

Parts description

1. Cover
2. Push buttons + display (behind cover)
3. Cover with venting
4. Venting
5. Cable entry
6. O-ring
7. Electronics housing
8. Foot
9. Lockring
10. Weld-on nipple (W) or Flange (F)
11. Packing
12. Flush diaphragm

Code W

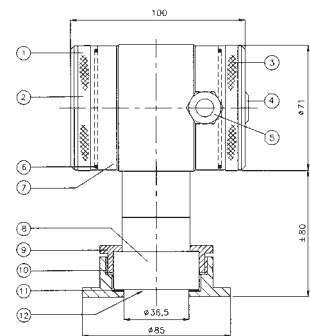

See page 6 for ordering code and ranges.

Peramic 'S' Series CER 2000

Description

The Peramic 'S', series **CER-2000**, is a pressure transmitter based on a *ceramic measuring sensor*. The CER-2000 series is fully temperature compensated and is made for all pressure applications in clean liquids, gases and vapours. The ceramic measuring cell *can withstand high overpressures*, and is sealed by an o-ring (viton as standard, other materials on request). Zero and span can be *adjusted without testpressure* over wide ranges, by 3 push-buttons or by a hand-held terminal (HART®, option).



Specifications

Accuracy	: 0,1% of adjusted span
Measuring ranges	: 0 - 0,2 bar to 0 - 320 bar
Output signal	: 4 - 20 mA / 2-wire HART® protocol (option) PROFIBUS-PA (option)
Adjustment	: by 3 pushbuttons or H.H.T.
Power supply	: 12 - 40 Vdc
External load	: 600 Ohm / 24V to 1400 Ohm / 40V
Protection grade	: IP66
Process temperature	: -20°C to 90°C
Temperature effect	: ±0,015% / K
Measuring sensor	: ceramic (Al ₂ O ₃)
Sensor sealing	: viton o-ring (standard) other materials on request
Other wetted parts	: AISI 316 (standard)
Material housing	: AISI 304

Process connections



Code R
1/2" BSP
(DIN 16288)



Code S
1/2" BSP M and
1/4" BSP F



Code N
1/2" NPT M and
1/4" NPT F

Dimensions (mm)

Code R

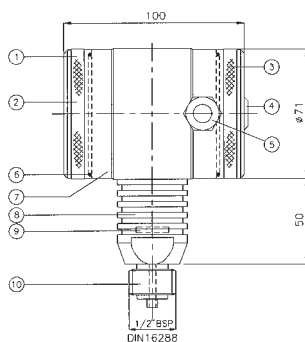

Parts description

1. Cover
2. Push buttons + display (behind cover)
3. Cover with venting
4. Venting
5. Cable entry
6. O-ring
7. Electronics housing
8. Foot with cooling fins
9. Ceramic sensor
10. Process connection

Code S

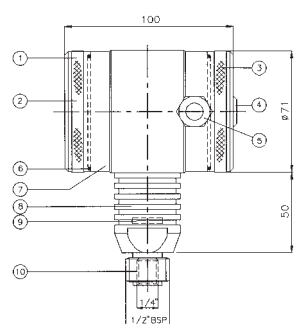

See page 6 for ordering code and ranges.

General information series 2000

Calibration

As standard the Series 2000 is always equipped with a display and 3 pushbuttons for easy calibration. Both the measured and the calibrated value can be read locally. A full calibration can be completed using the three push-buttons or with the optional handheld terminal (HART®), or with special software from Klay Instruments.



Zero and span can be calibrated very easy, without test pressure, also in vacuum ranges. Linearisation can be made for various tank shapes like horizontal and conical tanks (P111). For all other adjustable points see table right.

The series 2000 will as standard be delivered with 2 closed covers, so the 3 pushbuttons and the standard display are behind the cover.

A cover with transparent plastic can be delivered as an option (I). In that case you can use the display as a local indicator.



Easy Programmable

Display with 3 pushbuttons (Standard)

Adjustable points

- | | |
|------|---|
| P101 | Zero adjustment (4 mA) |
| P102 | Span adjustment (20 mA) |
| P103 | Cancel mounting position effect |
| P104 | Adjustment pressure unit
(see conversion table) |
| P105 | 4 - 20 mA *
20 - 4 mA (reverse output) |
| P106 | Damping adjustment (0 to 25 sec) |
| P107 | Indication of process temperature
(read out on display) |
| P108 | 0 = CELC °C *
1 = FAHR °F |
| P109 | Read out on display:
0 = current (4 - 20 mA) *
1 = pressure unit
2 = percent % |
| P110 | Current simulation (4 - 20 mA) |
| P111 | Linearisation
(Various tankshapes) |

* = factory setting

Certificates and options

Temperature Compensation

All our transmitters are fully temperature compensated. All Klay transmitters with flush diaphragm are equipped with the unique KLAY **Flush Diaphragm Technology**. (Detailed documentation available).

For **High Temperature Applications** where the process temperature is continuously above 100°C we manufacture special transmitters with cooling fins to reduce the temperature (Series 2000-SAN with HT option). With a compact 2000-SAN transmitter with option HT we can go up to 180°C and with separation by a cable between process connection and electronics housing (Type: 2000-SAN-Cable-HT) we can go up to 250°C continuously! The HT option is only available on series 2000-SAN (except range 1 and 2)



2000-SAN-HT



Orderingcodes 2000, 2000-SAN and CER-2000 series

SERIES 2000 (info on page 2)				SERIES 2000 -									
Ranges (bar)		Max. overpressure (bar)	Adjustable span range:		▲	▲	▲	▲	▲	▲	▲	▲	▲
0 - 0,1 ...0,4		6,4	0 - 0,1 to 0 - 0,4 bar		1								
0 - 0,3 ...1,2		10,5	0 - 0,3 to 0 - 1,2 bar		2								
0 - 1 ...10		30	0 - 1 to 0 - 10 bar		3								
0 - 5 ...30		100	0 - 5 to 0 - 30 bar		4								
0 - 20 ...60		150	0 - 20 to 0 - 60 bar		5								
PROCESS CONNECTIONS:										W			
- Weld-on nipple diam. 33 mm. (flush diaphragm / pulp & paper)										S			
- G1" (1" BSP) threaded connection (flush diaphragm)										X12			
- PASVE 1" connection (Valmet/Satron)										X..			
- Other process connections: i.e. PMC(X2), Valcom, Vega, etc. (specify X code)													
OPTIONS:										I			
- Transparent cover, display functions as local indicator													
- Vacuum Ranges (Specify Relative or absolute) Compound ranges available (example -1 / +1 bar)											V		
- Intrinsically safe: ATEX ⚡ II 1 G/D EEx ia IIC T4												Ex	
- HART® Protocol													H
- PROFIBUS-PA output (Not available in Ex)													P

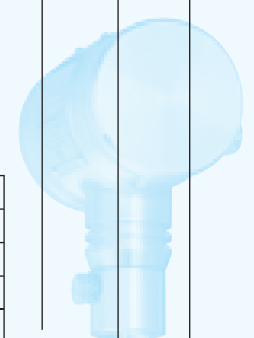

SERIES 2000-SAN (info on page 3)				SERIES 2000 SAN -									
Ranges (bar)		Max. overpressure (bar)	Adjustable span range:		▲	▲	▲	▲	▲	▲	▲	▲	▲
0 - 0,04 ...0,4		6,4	0 - 0,04 to 0 - 0,4 bar		1								
0 - 0,12 ...1,2		10,5	0 - 0,12 to 0 - 1,2 bar		2								
0 - 1 ...10		30	0 - 1 to 0 - 10 bar		3								
0 - 5 ...30		100	0 - 5 to 0 - 30 bar		4								
0 - 20 ...60		150	0 - 20 to 0 - 60 bar		5								
PROCESS CONNECTIONS:										M..			
- Milk coupling DIN 11851, DN 25 (only ranges 3 and 4), DN 40, DN 50 (all ranges)										W..			
- Hygienic weld-on nipple diam 62 mm or 85 mm (specify, for example: W85)										L..			
- Tri-clamp 1½", 2" or 3" (specify size)										F..			
- Flange: DN 25, 40, 50 or 80 (DIN) or 1½", 2" or 3" (ANSI) (specify size)										X..			
- Other connections: G1½"(X3), Varivent(X4), IDF(X5), DRD(X7), SMS (X9), etc... (specify X code)													
OPTIONS:										I			
- Transparent cover, display functions as local indicator													
- Vacuum Ranges (Specify Relative or absolute) Compound ranges available (example -1 / +1 bar)											V		
- HIGH Temperature version with cooling fins. Always specify Process Temperature											HT		
- Intrinsically safe: ATEX ⚡ II 1G/D EEx ia IIC T4												Ex	
- HART® Protocol													H
- PROFIBUS-PA output (Not available in Ex)													P

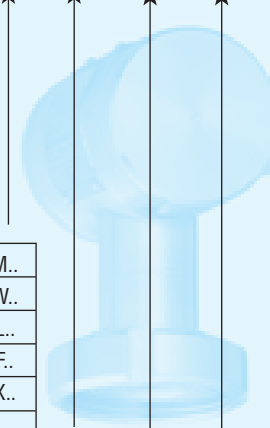

SERIES CER-2000 (info on page 4)				SERIES CER-2000 -									
Ranges (bar)		Max. overpressure (bar)	Adjustable span range:		▲	▲	▲	▲	▲	▲	▲	▲	▲
0 - 0,2 ...0,8		5	0 - 0,2 to 0 - 0,8 bar		1								
0 - 0,8 ...2		10	0 - 0,8 to 0 - 2 bar		2								
0 - 2 ...10		50	0 - 2 to 0 - 10 bar		3								
0 - 10 ...40		120	0 - 10 to 0 - 40 bar		4								
0 - 40 ...200		350	0 - 40 to 0 - 200 bar		5								
0 - 150 ...320		600	0 - 150 to 0 - 320 bar		6								
PROCESS CONNECTIONS:										R			
- G ½" (½" BSP) manometer (gauge) connection DIN 16288										S			
- G ½" (male) and G ¼" (female)										N			
- ½" NPT (male) and ¼" NPT (female)													
OPTIONS:										I			
- Transparent cover, display functions as local indicator													
- Vacuum Ranges (Specify Relative or absolute) Compound ranges available (example -1 / +1 bar)											V		
- Intrinsically safe: ATEX ⚡ II 1G/D EEx ia IIC T4												Ex	
- HART® Protocol													H
- PROFIBUS-PA output (Not available in Ex)													P

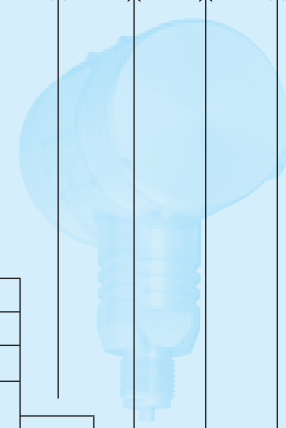

We reserve the right for technical modifications without prior notice.