

Portable Ultrasonic Flow Measurement of Gas

Features

Transducers

- non-invasive (no contact with the medium, no need for expensive materials)
- wearfree
- no pressure drop (no operational costs)
- low installation costs
- not sensitive to dust or humidity
- advantageous price for large pipe diameters and high pressure stages

Flowmeter

- portable flowmeter with rechargeable battery for service work
- wall thickness measurement (option)
- simple operation due to clearly structured user dialog
- calculation of standard volume flow

Measurement

- stable and reliable measuring results even under difficult conditions
- measurement is unaffected by density, viscosity and composition of the gas and by dust and humidity
- precise bi-directional flow measurement with high measurement dynamics
- long-term stable measurement results
- high measurement rate, fast response time

Common Applications

- operative measurement on natural gas pipelines
- operative measurement in natural gas production
- operative measurement for the gas supply
- measurement of injection gas in the oil industry
- measurement of synthesis gas in plastic production
- measurement of N₂, O₂, H₂



FLUXUS G6725



Measurement equipment in transport case



Wall thickness measurement (option)

Measuring Principle

For the flow measurement of the medium, ultrasonic signals are used, employing the transit time method. Ultrasonic signals are emitted by a transducer installed on one side of a pipe, reflected on the opposite side and received by a second transducer. These signals are emitted alternatively in flow direction and against it.

As the medium in which the signals propagate is flowing, the transit time of the ultrasonic signals in flow direction is shorter than against the flow direction.

The transit time difference Δt is measured and allows to determine the average flow velocity on the propagation path of the ultrasonic signals. A flow profile correction is then performed in order to obtain the area average of the flow velocity, which is proportional to the volume flow.

The received ultrasonic signals will be checked for their usefulness for the measurement and the plausibility of the measured values will be evaluated. The complete measuring cycle is controlled by the integrated microprocessors. Disturbance signals will be eliminated by statistical signal processing.

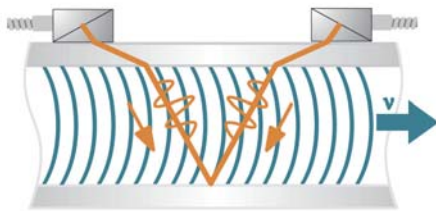

Path of the ultrasonic signal

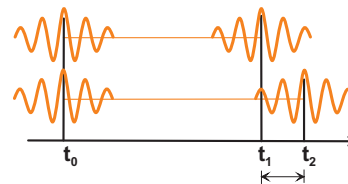

Transit time difference Δt

Calculation of the Flow Velocity

$$v = k_{\alpha} \cdot \Delta t / (2 \cdot t_t)$$

with:

v - flow velocity

k_{α} - flowmeter constant

Δt - transit time difference

t_t - transit time of the medium

Number of Sound Paths

The number of sound paths is the number of transits of the ultrasonic signals through the medium in the pipe.

reflection mode: number of sound paths = 2, the transducers are mounted on the same side of the pipe, correct positioning of the transducers easier

diagonal mode: number of sound paths = 1, the transducers are mounted on opposite sides of the pipe

The mode to be used depends on the application. If the number of sound paths is increased, the accuracy of the measurement will be better, but the signal attenuation is increased.

In case of a high signal attenuation by medium, pipe and coatings, diagonal mode with 1 sound path will be used.

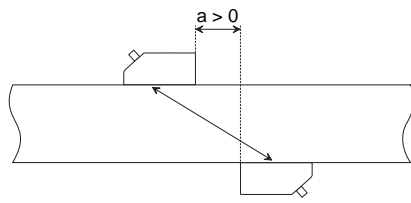

Diagonal mode, 1 sound path

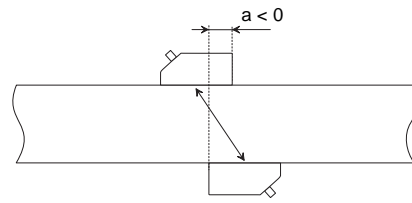

Diagonal mode, 1 sound path, negative transducer distance

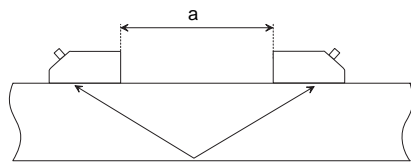

Reflex mode, 2 sound paths

a - transducer distance

Typical Measurement Setup

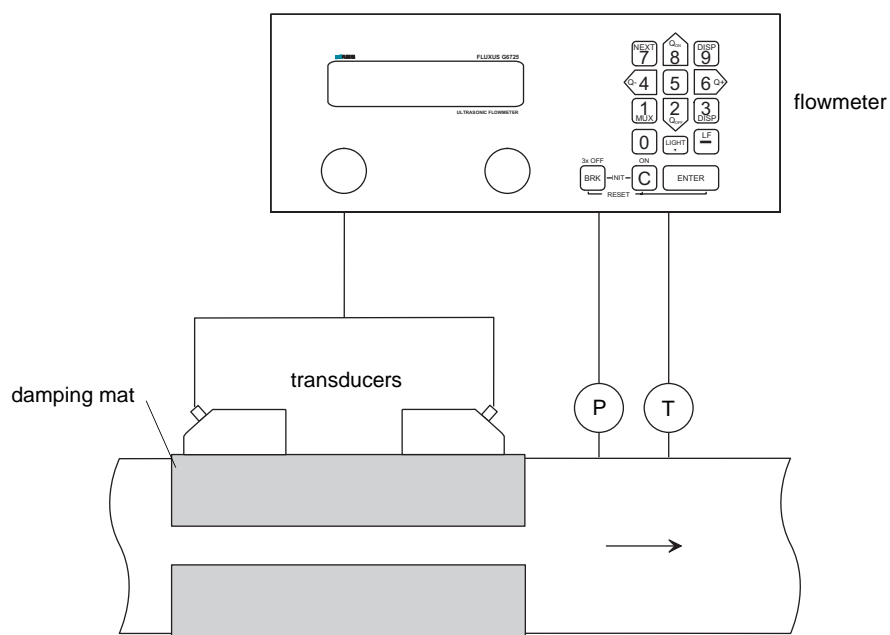

Gas flow measurement in reflection mode with FLUXUS G6725 using external process pressure and process temperature measurement for standard volume flow calculation

Standard Volume Flow

The standard volume flow of the medium can be selected as physical quantity to be measured. It will be calculated internally by:

$$V_N = V \cdot p/p_N \cdot T_N/T \cdot 1/K$$

with:

V_N - standard volume flow
 V - operational volume flow
 p_N - standard pressure (absolute value)
 p - operational pressure (absolute value)
 T_N - standard temperature in K
 T - operational temperature in K
 K - gas compressibility factor

The operational pressure p and the operational temperature T of the medium will be entered directly as fixed values into the flowmeter.

Or:

If inputs are installed (option), pressure and temperature can be measured by the customer and fed in the flowmeter.

The gas compressibility factor K will be entered in the flowmeter:

- by input of a fixed value or
- as approximation according to e.g. AGA8 or GERG

Flowmeter

Technical Data

FLUXUS	G6725
design	portable
	
measurement	
measuring principle	transit time difference correlation principle
flow velocity	0.01...35 m/s, pipe diameter dependent
repeatability	0.15 % of reading ±0.01 m/s
accuracy	
- volume flow	± 1...3 % of reading ± 0.01 m/s depending on application ± 0.5 % of reading ± 0.01 m/s with field calibration
medium	gases with a ratio of the characteristic acoustic impedances of pipe wall and gas < 3000
flowmeter	
power supply	100...230 V/50...60 Hz or battery
battery	6 V/4 Ah operating time (without outputs, inputs and backlight): > 10 h
power consumption	< 15 W
flow channels	2
signal damping	0...100 s, adjustable
measuring cycle (1 channel)	100...1000 Hz
response time	1 s (1 channel), option: 70 ms
material	aluminum, powder coated
degree of protection according to EN 60529	IP 54
dimensions	see dimensional drawing
weight	3.9 kg
operating temperature	-10...+60 °C
display	2 x 16 characters, dot matrix, backlit
menu language	English, German, French, Dutch, Spanish
measuring functions	
physical quantities	operational volume flow, standard volume flow, mass flow, flow velocity
totalizers	volume, mass
calculation functions	average, difference, sum
data logger	
loggable values	all physical quantities and totalized values
capacity	> 100 000 measured values
communication	
interface	RS232
serial data kit (option)	
software (all Windows™ versions)	- FluxData: download of measured data, graphical presentation, conversion to other formats - FluxKoeff: creating medium data sets
cable	RS232
adapter	RS232 to USB

FLUXUS	G6725
outputs (option)	
	The outputs are galvanically isolated from the main device.
number	on request
current output	
range	0/4...20 mA
accuracy	0.1 % of reading $\pm 15 \mu\text{A}$
active output	$R_{\text{ext}} < 500 \Omega$
passive output	$U_{\text{ext}} < 24 \text{ V}$, $R_{\text{ext}} < 1 \text{ k}\Omega$
voltage output	
range	0...1 V or 0...10 V
accuracy	0...1 V: 0.1 % of reading $\pm 1 \text{ mV}$ 0...10 V: 0.1 % of reading $\pm 10 \text{ mV}$
internal resistance	$R_i = 500 \Omega$
frequency output	
range	0...1 kHz or 0...10 kHz
open collector	24 V/4 mA
binary output	
Reed relay	48 V/0.25 A
open collector (OC)	24 V/4 mA
binary output as limit detector - function as state output	limit, sign change or error
binary output (OC) as pulse output - value - width	0.01...1000 units 80...1000 ms
inputs (option)	
	The inputs are galvanically isolated from the main device.
number	max. 4, on request
temperature input	
designation	Pt100
design	4-wire
range	-50...+400 °C
resolution	0.1 K
accuracy	$\pm 0.1 \%$ of reading $\pm 0.2 \text{ K}$
current input	
accuracy	0.1 % of reading $\pm 10 \mu\text{A}$
range	active : 0...20 mA passive : -20...+20 mA
active input	$U_i = 15 \text{ V}$, $R_i = 50 \Omega$, $P_i < 0.5 \text{ W}$, not short circuit proof
passive input	$R_i = 50 \Omega$, $P_i < 0.3 \text{ W}$
voltage input	
range	0...1 V or 0...10 V
accuracy	0...1 V: 0.1 % of reading $\pm 1 \text{ mV}$ 0...10 V: 0.1 % of reading $\pm 10 \text{ mV}$
internal resistance	$R_i = 1 \text{ M}\Omega$

Dimensions (in mm)

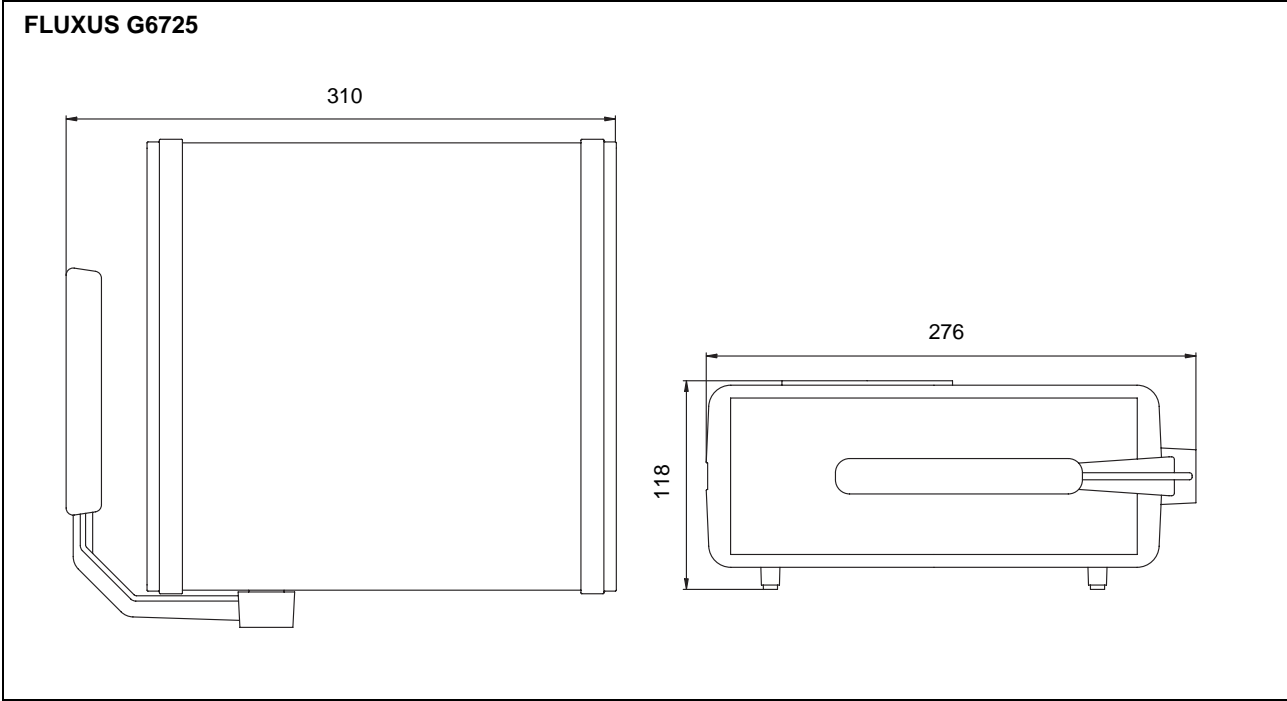

Transducers

Shear Wave Transducers

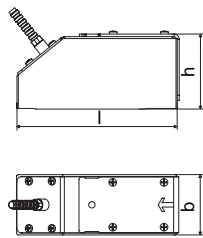
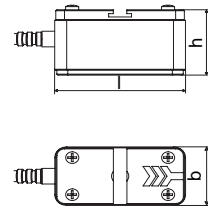
technical type		GDG1NZ7	GDK1NZ7	GDM1NZ7
order code		GSG-NNNNL	GSK-NNNNL	GSM-NNNNL
transducer frequency	MHz	0.2	0.5	1
min. operating pressure ¹	bar	30	30	40
outer pipe diameter ²				
min. extended	mm	250	70	30
min. recommended	mm	380	80	40
max. recommended	mm	810	500	80
max. extended	mm	1100	720	120
pipe wall thickness				
min.	mm	14	5	2.5
max.	mm	-	-	-
material				
housing		PEEK with stainless steel cap	PEEK with stainless steel cap	stainless steel
contact surface		PEEK	PEEK	PEEK
degree of protection according to EN 60529		IP 65	IP 65	IP 65
dimensions				
length l	mm	129.5	126.5	60
depth b	mm	47	47	30
height h	mm	66.4	55.9	33.5
dimensional drawing				
operating temperature				
min.	°C	-40	-40	-40
max.	°C	+130	+130	+130
explosion protection				
ATEX zone marking		-	-	-
certification		-	-	-
type of protection		-	-	-
FM marking		-	-	-
type of protection		-	-	-

¹ depending on application, typical value for natural gas

² shear wave transducers:
 typical values for natural gas, N₂, O₂, pipe diameters for other gases on request
 pipe diameter min. recommended/max. recommended/max. extended: in diagonal mode and for a flow velocity of 15 m/s

Lamb Wave Transducers

technical type		GRG1NC3	GRH1NC3	GRK1NC3
order code		GLG-NNNNL	GLH-NNNNL	GLK-NNNNL
transducer frequency	MHz	0.2	0.3	0.5
min. operating pressure ¹	bar	30	30	30
outer pipe diameter ²				
min. extended	mm	190	120	60
min. recommended	mm	220	140	80
max. recommended	mm	900	600	300
max. extended	mm	1600	1000	500
pipe wall thickness				
min.	mm	11	7	4
max.	mm	23	15	9
material				
housing		PPSU with stainless steel cap	PPSU with stainless steel cap	PPSU with stainless steel cap
contact surface		PPSU	PPSU	PPSU
degree of protection according to EN 60529		IP 65	IP 65	IP 65
dimensions				
length l	mm	128.5	128.5	128.5
depth b	mm	47	47	47
height h	mm	69.9	69.9	69.9
dimensional drawing				
operating temperature				
min.	°C	-40	-40	-40
max.	°C	+170	+170	+170
explosion protection				
ATEX zone		-	-	-
marking		-	-	-
certification		-	-	-
type of protection		-	-	-
FM marking		-	-	-
type of protection		-	-	-

¹ depending on application, typical value for natural gas

² Lamb wave transducers:
 typical values for natural gas, N₂, O₂, pipe diameters for other gases on request
 pipe diameter min. recommended/max. recommended: in reflection mode and for a flow velocity of 15 m/s
 pipe diameter max. extended: in diagonal mode and for a flow velocity of 25 m/s

Max. Flow Velocity

for a typical application with natural gas, N₂, O₂ in reflection mode with 2 sound paths (Lamb wave transducers)/1 sound path (shear wave transducers)

Shear Wave Transducers

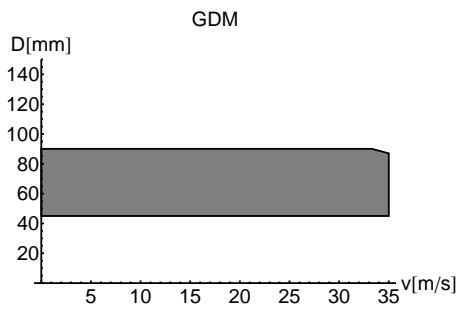
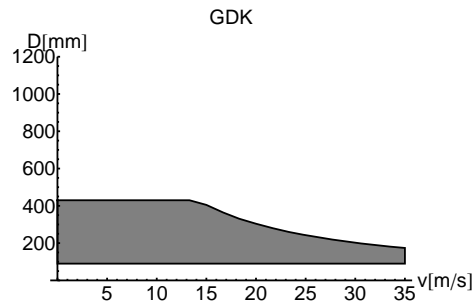
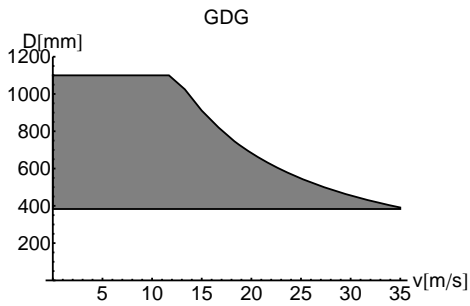

Lamb Wave Transducers

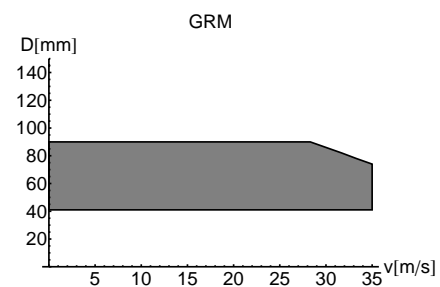
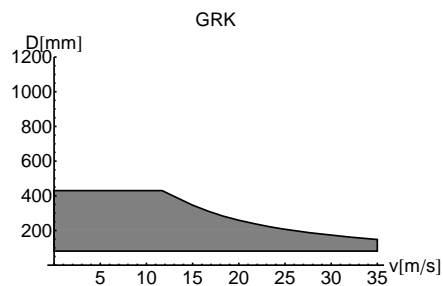
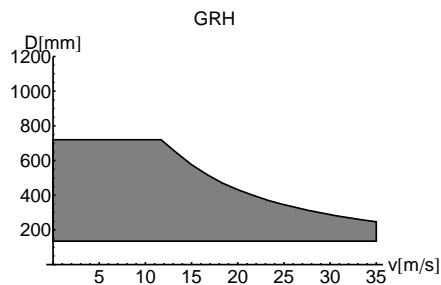
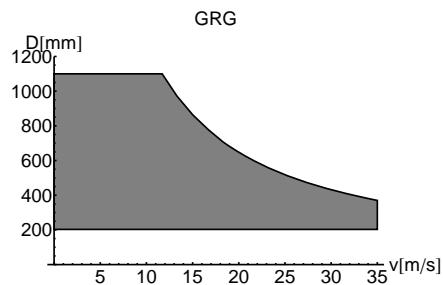

Order Code Key for Transducers

transducer model	frequency	-	temperature	explosion protection	connection system	-	extension cable	description
GL								set of ultrasonic flow transducers for gas measurement, Lamb wave
GS								set of ultrasonic flow transducers for gas measurement, shear wave
	G							0.2 MHz
	H							0.3 MHz (Lamb wave only)
	K							0.5 MHz
	M							1 MHz (shear wave only)
			N					normal temperature range
				NN				not explosion proof
					NL			with Lemo connector
							XXX	cable length in m, for max. length of extension cable see page 14
example								
GS	G	-	N	NN	NL	-	030	shear wave transducer 0.2 MHz, normal temperature range, connection system NL with 30 m extension cable and Lemo connector
		-				-		

Transducer Pipe Mounting Fixtures

Portable Variofix Mounting Fixture PVF and Chain

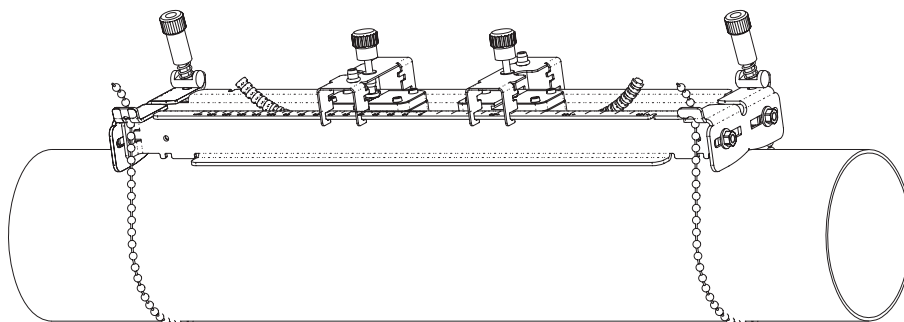

Portable Variofix Mounting Fixture PVF and Magnets (option)

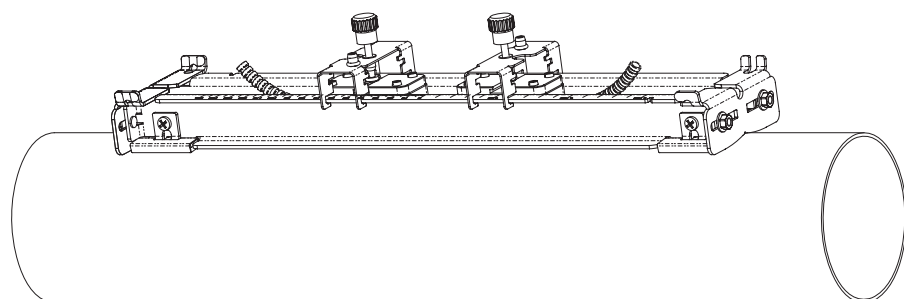

Damping Mats (Option)

Damping mats will be used for the gas measurement to reduce noise influences on the measurement.

Transducer damping mats will be installed below the transducers.

Pipe damping mats will be installed at reflection points, e.g. flange, welding.

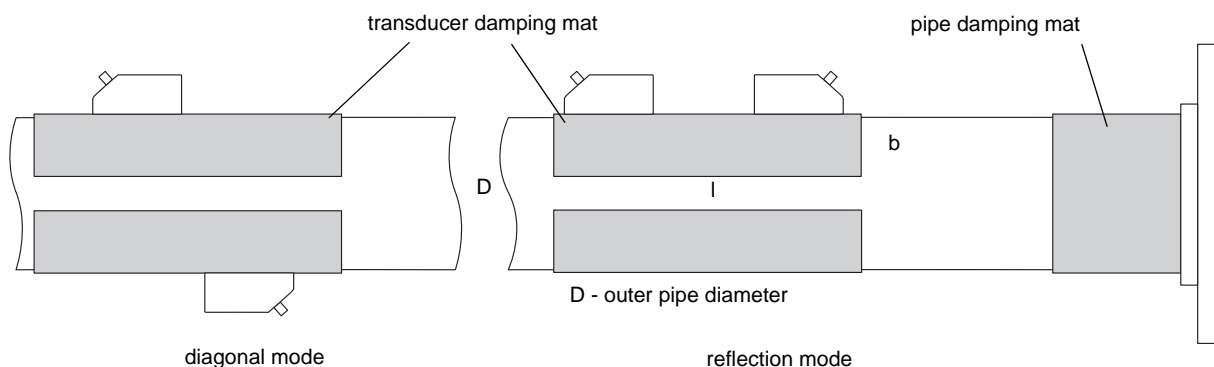

Selection of Damping Mats

type	description	outer pipe diameter mm	dimensions l x b x h mm	transducer frequency					technical type	temperature °C	remark
				G	H	K	M	P			
transducer damping mat											
D	for temporary installation (multiple use), fixed with coupling compound	< 80	450 x 115 x 0.5	-	-	-	x	x	D20S3	-25...+60	
		≥ 80	900 x 230 x 0.5	-	-	x	x	-	D20S2		
			900 x 230 x 1.3	x	x	-	-	-	D50S2		
pipe damping mat											
A	for temporary installation (multiple use), fixed with coupling compound	< 300	300 x 100 x 0.5	x	x	x	x	x	A20S4	-25...+60	for number of pieces see table below
B	self-adhesive	≥ 300	l x 100 x 0.9	x	x	x	x	x	B35R2	-35...+50	l - see table below

Pipe Damping Mat Type A: Number of Pieces Depending on the Outer Pipe Diameter

outer pipe diameter D mm	number	
	G, H	K, M, P
100	13	7
200	26	13
300	38	19
500	63	32
1000	126	63

Pipe Damping Mat Type B: Length l Depending on Transducer Frequency and Outer Pipe Diameter

outer pipe diameter D mm	transducer frequency	
	G, H	K, M, P
300	12 m	6 m
500	32 m	16 m
1000	126 m	63 m

Connection Systems

Connection System NL

transducer frequency		G, H, K			M, P			Q			S		
cable length	m	x	y	l	x	y	l	x	y	l	x	y	l
		2	3	≤ 100	2	2	≤ 100	2	1	≤ 50	1	1	≤ 20

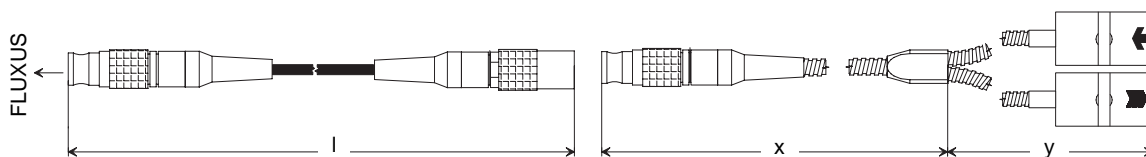

x, y - transducer cable length
 l - max. length of extension cable



FLEXIM GmbH
Wolfener Str. 36
12681 Berlin
Germany
Tel.: +49 (30) 93 66 76 60
Fax: +49 (30) 93 66 76 80

internet: www.flexim.com
e-mail: info@flexim.com

Subject to change without notification. Errors excepted.
FLUXUS® is a registered trademark of FLEXIM GmbH.
01.06.2008 TSFLUXUS_G6725V1-0EN